

# DRIVING ON WOOD

The Lost Art of Driving Without Gasoline  
Revised 2006, with Plans for Building a WWII Gasifier

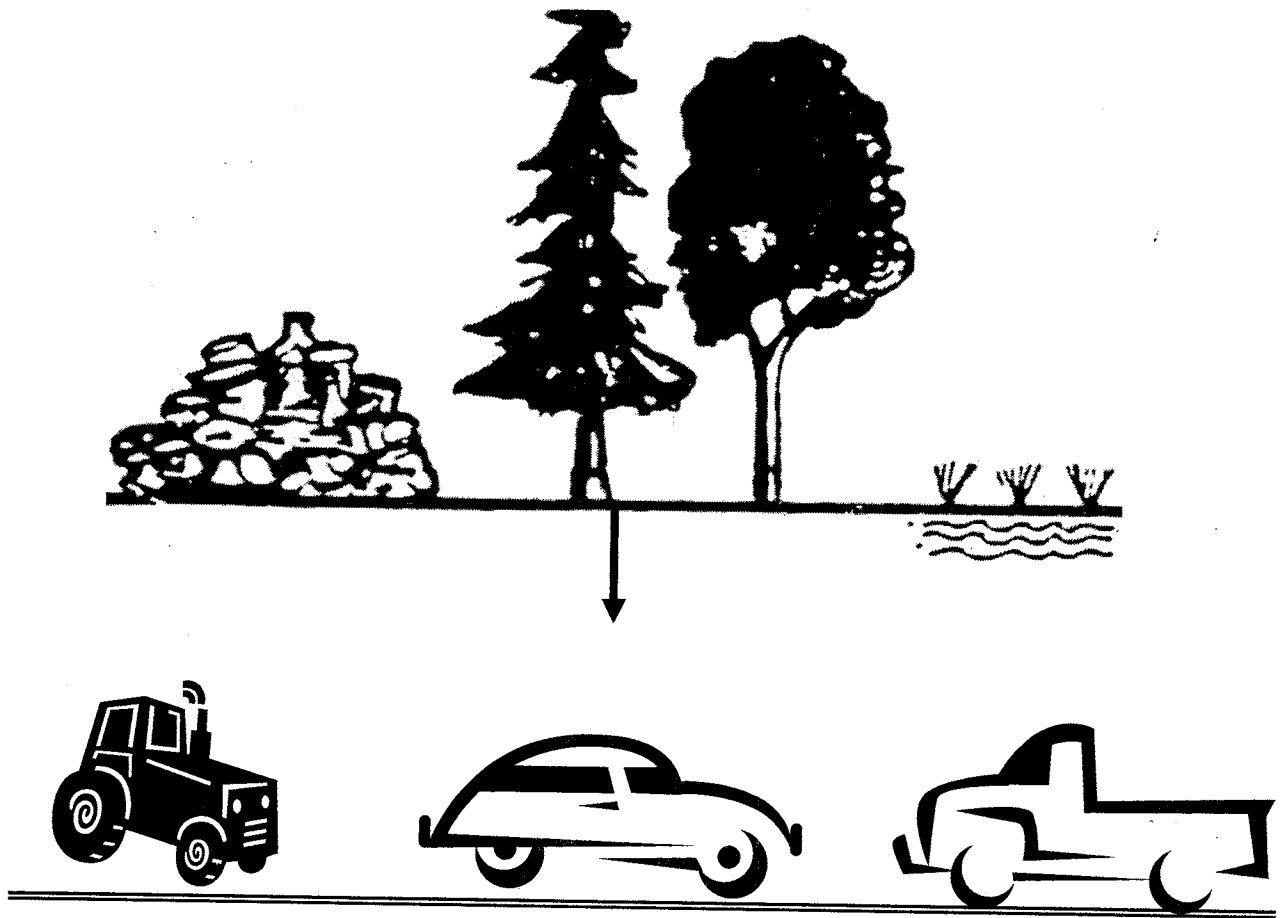

Niels A. Skov  
Mark L. Papworth

THE BIOMASS ENERGY FOUNDATION PRESS  
P.O. Box 1033, Franktown, CO 80116

This document, originally available as a bookstore publication of the former Biomass Energy Foundation, is now freely available as part of an archive of publications at <http://www.drtilud.com/resources>



# INTRODUCTION

You can use wood to fuel your car. It has been done before!

During WW II more than a million cars, trucks and buses were converted to run on "gasifiers", using wood blocks when the military took all the gasoline and diesel. Can you imagine a modern city without transport for people, goods and food? *It is possible!*

Now that the era of "cheap oil" is over, there is renewed interest in gasification (gasifiers?), primarily for generating electric power. However, if we don't start massive replacement of oil with synthetic/renewable liquid fuels, it could be an emergency measure even for transport again. Gasification is also the simplest route to making the liquid fuels, methanol and FT diesel from any carbonaceous material.

I have been working in the field of renewable energy since the first OPEC oil embargo in 1972, first at MIT, then at the Solar Energy Research Institute (SERI, now the National Renewable Energy Laboratory, NREL), then at the Colorado School of Mines, and now independently instead of retiring. It is my passion and dedication (after my family).

When I first started working on them, I thought I knew how to build better and simpler gasifiers. I have been learning a great deal about the chemical reactions involved, the temperatures required, and how to operate them. However, I have recently developed new respect for the WWII downdraft gasifier, both because of its record of success and because it solves problems automatically that other gasifiers can only solve with modern control systems.

The gasification process involves first the flaming pyrolysis of the fuel to produce gas and charcoal, followed by the reaction of the gas with the charcoal to reduce  $H_2O$  and  $CO_2$ , formed during the flaming pyrolysis, to  $H_2$  and  $CO$ . If the gasifier is to operate in a steady state for long periods, these processes need to be kept in balance. The Imbert gasifier accomplishes this by introducing air to the reaction zone with 5 or more nozzles. If too much charcoal is being produced, the air primarily reacts with this charcoal to make  $CO$  and  $H_2$ . If too little charcoal is made, the incoming air meets fresh biomass and increases charcoal production. While other gasifiers have been developed since World War II, these gasifiers have a simplicity that keeps them relevant; they are being produced and used in India and China today.

~ ~ ~

This book was initially published in 1974 by Pegasus Publishers, Inc. in Olympia, Washington. It first appeared under the title "The Pegasus\* Unit: The Lost Art of Driving without Fuel" and the \* told us "PEGASUS" was an acronym for Petroleum/Gasoline Substitute Systems. We have taken the liberty of changing the title to be more self-explanatory.



Many other books on gasification have been published since then, (see our list at the end) but this remains a favorite for giving detailed drawings of the working systems used during World War II (mostly charcoal gasifiers) and the detailed plans for building a representative wood gasifier. It is being re-issued by the Biomass Energy Foundation Press as part of our program to keep books on gasification in print.

I talked to one author, Prof. Niels Skov, by telephone at Evergreen College several years ago. He told me that the gasifier shown in the plans was fitted to a Checker Taxicab and ran well for students and in demonstrations. For the correct sizing of this type of gasifier to other engines, see p. 37 of our "Biomass Downdraft Gasifier Engine Systems Handbook," which also describes the principles and construction of other parts of the system.

The Imbert (nozzle) type gasifier is again being produced in India and China. It is simple to construct and operate for anyone skilled in metal working. We wish you good fortune in building one.

--Tom B. Reed, Ph.D.

## **ACKNOWLEDGEMENTS**

These acknowledgements appeared in the first edition: "For valuable assistance in gathering technical data and information, we are indebted to Carlo Thomsen of Virum and Aage Kjellerup of Fredericia, Denmark. For typing and proofreading the manuscript, our gratitude goes to Donna McMaster of the Evergreen State College.

Our founder, Dr. Harry LaFontaine also was Danish and knew and worked with Niels Skov. He later acquired rights to the publication of this book.



# TABLE OF CONTENTS

	PREFACE	9
CHAPTER I	OUT OF GAS	11
CHAPTER II	THE LOST ART	19
CHAPTER III	PRINCIPLES OF SOLID FUEL CONSUMPTION	34
	General	34
	Air Gas (semi-combustion)	36
	Mixed Gas	41
	Steam Dissociation	42
	Combustion of Carbon with Dissociated Steam	44
	The Gasification Diagram	44
CHAPTER IV	FUNCTIONING OF THE PEGASUS UNIT	47
	Processes in the Stack	47
	Calorific Value Transfer	51
	Influence of Gasification Temperature	52
	Effect of Air Velocity	53
	Addition of Steam	53
	Processes Outside Gasification Zone	55
	Inertia in the Processes	56
CHAPTER V	THE HEAT BUDGET	58
CHAPTER VI	THE FUELS	61
	Available Choices	61
	Wood	63
	Charcoal	64
	Coal	64
CHAPTER VII	FUEL CHARACTERISTICS	66
	Grain Size	66
	Bulk Weight	67
	Dust	68
	Tar Content	69
	Moisture Content	69

Ash and Slag 71  
Reaction Response 73  
Stability of Combustion 75

CHAPTER VIII	PEGASUS TYPES	78
	The Methods of Gasification	78
	Updraft	78
	Downdraft	82
	Crossdraft	84
	Other Possibilities	87
CHAPTER IX	THE GAS	88
	Composition	88
	Calorific Value	89
	Quantity	91
	Temperature	91
CHAPTER X	DESIGN OF A VEHICLE PEGASUS	93
	General System Considerations	93
	The Pegasus Unit	95
	The Air Stream	106
	Steam Injection	108
	Auxiliary Components	109
	Miscellaneous	112
CHAPTER XI	SOME SYSTEMS OF THE PAST	113
	Table of Conversion	126
	Metric Units	127
	Explanation of Units Used	128
	Index	129
	Bibliography	132







## PREFACE

As the Nazis prepared for war in the 1930s, German engineers and scientists were handed the problem of meeting propulsive energy needs if imports were cut off. They went at it with a Teutonic vengeance and eventually came up with the solution of gasifying substitute fuels, notably wood, peat and coal. Soon, engineering texts were peppered with exhortations to use only those energy sources that were plentiful within the borders of the Reich.

The systems were less convenient than gasoline, but they worked. When the German war machine ground to a halt in the spring of 1945, gasoline was all but a distant memory in occupied Europe. The busses and other motor vehicles necessary to keep the war time economies functioning, and even many German army trucks and tractors, had long since been converted to substitute fuels.

As Eisenhower's armies restored European freedom and petroleum again flowed in the arteries of industry and commerce, the substitute systems—known in Denmark as “stoves”—were gleefully thrown on the trash heap. They were after all symbolic of war time want and deprivation. It is therefore one of the ironic turnabouts of history that this 40-year old technology should now be gaining new currency.

During World War 2, I traveled many miles in wood gas powered vehicles. I learned about the substitute fuels first as a young engineering student in Copenhagen and later as a slave laborer under Nazi tutelage. The scent of a barbecue fire still takes me right back to those days.

When Mark and I embarked on writing this book, we decided to take it beyond a mere technology review, placing it instead in the relevant time frame of present day American needs and potentials. Our store of substitute fuels is different from those of Hitler's Germany, and improved designs are possible with the lighter, heat resistant materials developed over the last three decades.

We have stayed within the metric system to simplify design calculations and because it seemed appropriate in a work which attempts to look into the immediate future. We have standardized the generic designation for these units because there is no succinct English term for them. They were defined by various jawbreaking agglutinations of Wood-Coke-Air/Gas-Heater-Generators. We settled on PEGASUS, contracted from Petroleum/Gasoline Substitute Systems as both short and descriptive.

Knowing the enormous amount of collective ingenuity and

initiative this nation possesses, I have no doubt that Americans will seize and improve upon the fuel substitute technology to the point of ultimate perfection. The potential for pegasus units lies not just in wheeled vehicles but in virtually every combustion engine used, perhaps even elsewhere, too. The other day a fellow yachtsman pointed out to me how cozy a pegasus would be on a boat, doubling as heater and fuel producer while burning sundry driftwood and flotsam. He is right, of course. And it is already technically feasible for you to read your morning newspaper and then use that same paper to power your automobile to commute to work.

The prospects opened by the pegasus are fascinating indeed.

Olympia, 15 July, 1974  
Niels Skov

# Chapter I

## OUT OF GAS

We ran out of gas in the winter of 1973. It was also the winter of the appearance of the comet Kohoutek. Both events were widely forecast scientifically and in the press. Many people found Kohoutek a great disappointment after the marvelous speculations which were so widely circulated. They failed to appreciate its unspectacular scientific importance. No one, however, failed to grasp the full significance of the "temporary" gas shortage, and while Kohoutek failed to light the sky and sailed back out of human consciousness, the gasoline shortage, whether temporary or permanent, stayed with us.

There have been so many reviews of the energy resources crisis that it is difficult to choose among them. We have been buried by tons of books and articles reviewing the energy crisis and the status of our fossil fuel reserves. Each new proclamation paints a darker picture of our future. The editors of Science magazine devoted the entire issue of April 19, 1974, to consideration of the energy crisis by the prestigious membership of The American Association for the Advancement of Science. Here is an outline of the gasoline shortage as they summarized it for us:

*"When people are willing to appear at 5 a.m. at a station that is not scheduled to open until 8 a.m., they convey a message about the importance that many people attach to their automobiles. In part the attachment is economic. To many people, auto transportation is essential to their livelihood. In part the attachment is emotional. Whatever the source of the demand, it would be politically impossible to force people this summer to get along on supplies as limited as those of February 1974. In future years as people adjust, as they change to vehicles consuming less gasoline, the acceptable level of supplies may drop. For this year and probably the next few years, a minimum acceptable daily consumption averaged over the whole year is about 6.2 million barrels a day or about 5 percent less than we consumed in 1973. Such a level would entail tension and grumbling.*

*"Because of the central role of gasoline in energy problems, special efforts should be made both to decrease demand and increase supply. Had we been driving smaller, less gas-consuming cars, there would have been no energy crisis. Some other forms of transporta-*

*tion consume less gasoline, and their use should be encouraged.*

*"In principle, the oil companies could increase the yield of gasoline from crude oil. This would require changes in refineries. Today about 10 percent of the energy of crude oil is used in providing heat for the refining processes. In principle, this heat could be furnished by coal. Through more intense input of hydrogen in the cracking process, larger yields of gasoline could be obtained. One refinery expert has guessed that yields might be raised to as high as 75 percent from the present 48 percent. Such a shift would entail other shifts in the product patterns and in the consumption of hydrocarbons.*

*"The barriers to increased yields are costs and time, but these can and should be overcome. Petroleum is too important to be used merely as a source of heat."*

—(Philip H. Abelson)

That we do indeed waste much of our light distillate petroleum on the production of electrical power is made clear by Hans Landberg in the same issue of *Science*. We were unable to foresee the rate at which petroleum demands would rise because we could not know how the long range effects of our growing population would be expressed in petroleum usage. We exhausted our home resources and forced us imports increasing our dependency on Arab oil.

*"What has pushed imports up so far and so fast? One item has been the shift of electric utilities to oil, highly notable along the Atlantic Coast, and evident in the most spectacular manner in the Greater New York City area, where Consolidated Edison and Long Island Lighting relied on oil for 22 percent of their fuel input in 1960 and for nearly 80 percent in 1971. Controls imposed on emissions from plants that burn fossil fuel, the absence of a commercially viable technology for removing sufficient sulfur compounds from stack gases, and the tightness of natural gas supplies have caused utilities to shift to oil, which enables them to meet the restrictions imposed. The effect on prices is not surprising. In the Middle Atlantic region, cost to utilities of oil "as burned" rose 54 percent per barrel between 1969 and 1971, in*

*constant dollars. Various industrial users have turned to oil and, within that category, to the less polluting, lighter distillates. This in turn has caused a tightening of oil available for heating.*

*"At the same time, automobiles, which account for nearly 40 percent of oil consumed in this country, have become less efficient converters of gasoline into vehicle-miles. More power-consuming accessories on more cars (power steering, power brakes, air conditioners, and, more recently, emission control devices) are diverting part of the power produced from the drive shaft. These devices also have added to the car's weight, so that the same number of gallons will pull the car fewer miles, and there are more automobiles. Moreover, miles traveled per car per year have shown a moderate increase, after years of stability and despite the emergence on a rising scale of the two-and three-car family. Congestion in city streets and on highways adjacent to metropolitan areas could well have been another factor in lowering mileage per gallon. (Table 4).*

*"These factors have boosted demand for petroleum products. Gasoline demand rose by 2.6 percent per year from 1960 to 1965; it has risen at 4.5 percent since. From 1967 to 1972 it rose by 27 percent, or 4.9 percent per year. Consumption of residual fuel oil, the one-time Cinderella of refinery products that had risen by barely 1 percent per year from 1960 to 1965, shot up by an annual 7.2 percent over the latest 5-year span. This is the story for 1972, in percentage increases over 1971: gasoline, 6.0 percent; distillate, 8.5 percent; residual fuel oil, 10.1 percent; and total product demand, 7.3 percent."*

It may be years before we settle the matter of cause and effect in our new relationship to our petroleum resources. There is a growing concern, however, that it may only be months before the full significance bursts upon us. We are feeling our way into a new era; one which is painfully different from any prior experience of the American people. We have been the big spenders. We were the free living energy millionaires and we have suddenly been told our money is no good.

Money for Americans has always meant cars. The depth of our involvement with the automobile has not been realistically examined. Many social scientists have commented on our love affair with

speed and power and we admit to one another quite openly to being seduced by each year's sexy, gleaming new models. But no one has really measured our dependency and our concern. If forces could combine to deal a drastic blow to the American way of life, they would do most damage by hitting us right in the automobile. We have had a little taste of this in the recent crisis and we had an opportunity to see how we would respond.

Our responses were predictable in some ways and somewhat surprising in others. Hoarding became a national problem for the first time since World War II. Our national character stood forth in long lines which formed at service stations lucky enough to have gasoline. Yankee ingenuity produced con men who were reported to have installed fifty gallon tanks in their big cars and slyly requested attendants to "Fill 'er up." Many people used up their gas looking for gas—so they would not run out. And several people were shot. But, if we acted predictably in these episodes of Americana, we also showed a side of ourselves which we generally reserve for national emergencies. We hyper-individualistic, free enterprise, Bill of Rights Americans docilely slowed down to 55 mph and imposed citizen's arrests on one another to enforce our new driving rules. We proved that we can be mobilized to give up our long love affair with speed and power. All at once the national symbol of American conspicuous consumption, the Detroit Behemoth lost its sex appeal. The huge machines that were within the reach of all and proved every man's equality will soon become museum pieces.

Americans are now where Europeans have long been—with some differences. Europe has always had limited refinery capacities compared to ours and traditionally high European petroleum prices were the expectable results. We recently embarked upon the same economic adventure watching our refining capacities dwindle until the crisis level was reached. Whether this is to be applauded as the finest expression of free enterprise in an open market or lamented as a woeful abandonment of governmental responsibility remains to be seen. The economic facts of our energy crisis are very real and very potent. The additional spectre of shrinking world petroleum resources complicates our entry into an era of relative scarcity.

Alternative energy resources absorb a great deal of our technological attention these days. The Atomic Age has been a source of awesome promise for the past thirty years. Our scientists and engineers are working overtime on the first and most obvious nuclear energy source, the nuclear reactor, which taps the energy released in



the fission of uranium atoms. There are already twenty-eight commercial nuclear power plants in the United States, forty-nine more are under construction and sixty-seven are on order. We look forward confidently to the perfection of breeder reactors which will preserve scarce, inexpensively available uranium. Yet there are enormous problems in the mechanics of fission engineering. Hot waste, safety precautions against breakage and leaks, new metals to withstand radiation bombardment and heat problems are just a few areas of concern. Fusion reactors are a siren's song beyond the reach of the best efforts of our engineers and scientists. There are some 200 experimental programs going on in 14 countries attempting to harness the enormous energy of thermonuclear power. But we have never tackled a more difficult problem. It is the secret of the sun — the process by which solar energy fuels the entire chain of life. If and when it is harnessed, electrical energy shortages will be over forever.

Fuel cells which were developed in our space flight programs are self contained sources of electrical energy which some day may provide us with individual power plants for each of our homes doing away with power lines and their inefficient central power stations.

Magnetohydrodynamics substitutes a rotating super-heated gas for the rotating copper coils of an electrical generator. It is said to be one and one-half times as efficient as conventional fossil fuel powered plants.

The oceans are regarded as an inexhaustible source of power if it can be tapped. Deuterium, the fuel for fusion reactors, comes from sea water. In addition, capturing the tremendous energy of the tides has long been an ambition of the world's scientific community. In fact, the world's first large-scale tidal power plant is in operation in Brittany producing a respectable 240,000 kilowatts for the surrounding communities.

Geothermal power promises to achieve the controlled release of the boundless heat energy of the interior of the earth. Several fortunately situated communities such as Reykjavik, Iceland already enjoy the benefits of fuelless heat for their houses and steam power for their electrical needs.

Solar energy can be trapped in sunshine and converted into heat and its energy byproducts with virtually no pollution resulting. If we can perfect our neophyte techniques for retaining and transforming the energy of the sun into forms suitable for human needs, we will have opened the door to yet another endless reserve.

Each of these technologies holds great promise for the future and no immediate relief from our present shortages. An entire generation will be born and grow to adulthood while we wait for these changes. Our lives are tied to our world as it is today and we must meet its challenges with what we have on hand. While we feverishly experiment with techniques for the distant future, we are not preparing for the grim realities of tomorrow. We cannot direct our own technological progress. We cannot plan for all of the exigencies growing out of the complex interrelationships of our technological world. If we reduce mortality without controlling reproduction, the population explodes. If we reduce air pollution, we run out of fuels. And so on. In *The Limits to Growth*, the report of the Club of Rome's project on the predicament of mankind in the foreseeable future, we are told:

*"—preparation for technological change requires, at the very least, a great deal of time. Every change in the normal way of doing things requires an adjustment time, while the population, consciously or unconsciously, restructures its social system to accommodate the change. While technology can change rapidly, political and social institutions generally change very slowly. Furthermore, they almost never change in anticipation of a social need, but only in response to one."*

War is an obvious example of how societies have undergone great technological changes in the face of urgent needs for new devices. Since the coming of the industrial age, we talk of wars as being won or lost through production. Mobilizing an entire population for defense is an enormous and terrifying undertaking releasing forces which may wreck the society in the name of saving it. We simply lack the political machinery for getting ourselves into gear gently.

Another condition requiring the rapid acceptance of a new technology is found along a continuously expanding frontier. New, cheap energy resources are needed to exploit a seemingly endless natural resource. The most dramatic instance of this condition that the world has ever seen was the westward growth of the United States. It was a European free-for-all, a cross-continental foot race for the world's biggest prize, unlimited wealth. The new technology which was born in this great explosion was the reciprocating gasoline

engine. Steam powered tractors, trains and ships were quickly obsolete once petroleum fuels were plentiful, practical and cheap. The gasoline engine found a home in the wide-open spaces of America's heartland. We drove out of the past into the present and we are not about to park our old-familiars without a fight. The facts of our future are these: (1) we are not going to stop driving, and (2) we are not going to stop driving the vehicles that we have been driving and depend upon for so much of our livelihood.

Electrical cars and efficient mass transit systems are undoubtedly part of the future, but what are we to do while we are waiting? The reciprocating gasoline engine is here now, it works, and we have an enormous investment in it. We are not going to throw it out. If anything, we will find ways of using it more efficiently and, as it becomes more efficient, we will use it more widely as we wait for atomic reactors and solar energy resources to become available. The only problem that we face is a shortage of gasoline and diesel fuels. If we can run the same engines on alternate, renewable fuels we can ease the transition into the future, and, incidentally, preserve the individual freedom enjoyed by each American acting as his own private transportation company.

There is yet one further consideration for petroleum/gasoline substitute systems in the future. Under-developed areas are going to remain relatively poor for many years. Emerging Africa and the East are going to be dependent upon the dominant technologies of the old industrialized world for decades to come. The rift between rich nations and poor nations is going to become more pronounced rather than to be equitably reconciled by effective, authoritative international planning. As petroleum resources become scarcer, rich nations will simply pay more for their fuel, up to astronomical levels which we shall find hard to believe but yet which we shall pay. It will still be more economical than converting an enormous part of our technological base. We will continue to use and to manufacture our gasoline and diesel engines and their maintenance support systems. The poorer nations will be forced to live on the fringes of our involvement with fossil fuels. They will be forced to depend on our engines while not being able to afford the liquid fuels. It is likely that the needy of the near future will be those most interested in developing the pegasus unit. This relationship has numerous historical precedents. Anyone who has traveled in the "out-back" regions of the world can attest to the ingenuity with which kerosene driven vehicles were kept running several generations beyond their European manu-

facturer's wildest dreams. The World Power Conference in London reported in 1928 the successful installation of a pegasus unit at a mine in south Africa where it was practically and efficiently firing the petroleum fuel power units which served as their sole source of power, since they were far out of reach of hydro-electrical power or the economical importation of liquid fuel. We may see this day once again and sooner than we thought one short year ago.

On a background of numerous attempts at the perfection of steam driven vehicles in America, most of the descriptions from abroad were attributed to some sort of steam cars that were certain to be inferior to American products and not worthy of serious attention. But in those backward regions out of the mainstream of European technology, alternatives to highly refined fuels were a prime consideration and serious business from the first introduction of automotive technology.

It requires approximately 150 million dollars to build a modern refinery that will function at a profit. It was relatively as expensive to build refineries at the turn of the century when processes were less efficient. Whatever the final dollar cost of such an industrial development, the outlay was unthinkable in most of the underdeveloped world. In these regions, the early pegasus designers were eagerly accepted. In Europe the work of pioneer pegasus designers was hurriedly passed over in favor of the more efficient and handier liquid fuel burners, but the few European pegasus machines that made their way to such far off places as Africa, India and the Far East were looked upon as wonders of speed and power.

They remained poor relations at home. By the 1920's some European manufacturers were fabricating parts from which pegasus installations could be assembled, but nobody was mass producing the entire apparatus. Furthermore, each make of engine required its own peculiar adaptation to non-liquid fuel. By 1930, pegasus units were familiar to virtually every automotive manufacturer in Europe. None considered them vital parts of their industry, but they were kept on file by many of the engineering staffs. Europeans were always somewhat uneasy about their dependence upon foreign petroleum resources—a situation unfamiliar to oil-rich Americans.

When war brought the anticipated shortages to reality, European manufacturers were able to come forth with mechanical alternatives which the populations were psychologically ready to accept.

## Chapter II

# THE LOST ART

### *EUROPEAN BEGINNINGS*

The process of air gasification is as old as steel. In fact, the first attempts at industrial utilization of combustible gases produced in the reduction of organic fuels occurred in the blast furnaces of the industrial revolution. England led the way in devising air-gas generators for stationary units more than 175 years ago. The original air-gas generator was the blast furnace itself. In it iron was reduced by smelting with coke. The gases produced from the coke were highly combustible under the right conditions. By the year 1800 the gases produced from the coke were tapped off the chimney and fired to heat the molds into which the molten iron was poured. Later this gas was used to preheat the air which was forced through the hearth causing the coke to glow at temperatures up to three thousand degrees. This utilization of preheated air made the production of steel practical. One of the common pegasus designs is fundamentally similar to the blast furnace although the air flow is reversed. Fixed installations associated with blast furnaces commonly use purified air-gas tapped off the furnaces in this way to run gas engines. But this was a later development. Engineers became acquainted with the potentials of this gas resource first in other applications.

Gas produced from the reduction of coal, charcoal and peat was used for heat production as early as 1840. Gas generators were constructed for this task independent from the blast furnace. The first units of this type were installed at Wurttemberg and Steiermark, using lignite and charcoal. These early German machines served as the prototypes for more refined stationary gas generators using coke and anthracite exclusively for the production of heating gas.

Aside from industrial heat production, the first reports of using air-gas to fuel gas engines are found in England in about 1884. By 1890 the "Suction Gas" engine was developed from the English beginnings. In the suction gas engine, the air is drawn through the hearth for combustion, then through the subsequent filtering apparatus by the action of the engine's pistons. This is the basis of all of the subsequent pegasus units due to its simplicity. It is efficient enough to be constructed as self-contained, readily transported units. These suction gas engines were produced in numbers by German firms around the turn of the century. The first engines were at least on a par with steam engines of the same relative power in terms of economy and efficiency. In addition, they could be run on small grained fuels which caused difficulties in the furnaces of steam boilers. They could also consume reject materials such as plant fiber,

cotton bolls, rice and wheat chaff, etc., along with their normal diet of coal and coke. The handier liquid fuels, however, quickly gained acceptance in the growing gas vehicle industry and air-gas fueled units remained stationary despite their economy and efficiency.

There were early indications that assumptions of unlimited petroleum resources were dangerous for European nations without secure oil holdings and reserves. Germany faced brutal shortages of fuel in the late days of World War I. By 1917, Germany was well aware of the need to develop alternative fuel resources for their gas driven technology. It was a lesson and an impetus to further pegasus research. The war ended too soon for the research engineering prompted by these shortages to have any lasting effect. Gasoline returned as the most desirable vehicle fuel as soon as it could be supplied and another competitor, the diesel engine, threatened to press air-gas devices into obscurity.

In 1892, Rudolf Diesel, a German engineer born in Paris, took out an English patent on a device which would, in his own words, do

“motive work by means of heated air . . . compressed to so high a degree, that by the expansion subsequent to the combustion the air is cooled to about atmospheric temperature, and that into this quantity of air, after its compression, fuel is gradually introduced . . . at this compression the temperature becomes so high that the fuel employed is spontaneously ignited when it comes into contact with the compressed air.”

This engine succeeded in lowering the temperature of the exhaust gases and controlling the maximum temperatures at combustion by the revolutionary sequence of fuel introduction. Building on the successful four-cycle engines developed by Otto and bearing his name (although they too were based upon the inventions of numerous French and British predecessors), Diesel succeeded in reaching a much higher compression by using pure air in his cylinder, unmixed with fuel during the compression stroke and adding a premeasured injection of fuel oil at the top of the compression stroke where it ignited spontaneously on contact with the compressed air. It was found to work with almost any petroleum oil, and that its thermal efficiency was about 10% greater than any other form of engine of this period. But it was necessarily heavier in terms of its horsepower, requiring much stronger designs with much heavier finished units containing the unusually high compressions and the engines were

not intended to be useful in attaining high speeds. The maximum out-put was to be measured in only hundreds of revolutions per minute, leaving the race for high speed engines to the gasoline driven designs. But the diesel's obvious advantages over steam doomed the heavy, stationary steam engine throughout the industrial world. The diesel similarly pushed out the pegasus unit in its early industrial applications, and it was lost from the mainstream of engineering interest in the race to improve the gasoline engine.

Daimler, Peugeot, Benz, Lanchester, Renault and many other early pioneers standardized the formula for a successful, lightweight gasoline powered engine suitable for installation in light vehicles of all kinds. From the late 1890's on, the problems which gasoline engine mechanics faced were largely logistical. The principles had been discovered. It remained to make them work and to make them work ever more efficiently.

Eclipsed by the popularity of the gasoline engine, the pegasus unit remained a curiosity except in special circumstances. One set of circumstances which made the pegasus unit desirable existed in the colonies which were profitable for their European overlords only insofar as they were free from economic dependence upon their masters. Providing highly refined fuel to the colonies for the operation of the machines which extracted their wealth cut into the extremely favorable balance of trade that those European rulers enjoyed. From 1920 to 1930 those countries which desired to promote transportation systems in their colonial possessions experimented with the pegasus unit as a means of making their colonies independent of hard to supply and expensive petroleum. France, England and Italy built the first pegasus units for vehicles in response to this colonial need.

A principal advantage of the pegasus which is of critical importance today emerged from these early experiments. The fuel costs of pegasus units were substantially lower than highly refined petroleum products. With increasing scarcity, but, more importantly, with the increasing price of petroleum fuels, this advantage remains important today—particularly in those poor countries who will not be able to pay for expensive gasoline if the price continues to rise as a function of scarcity or because of the exorbitant prices fixed by the major oil companies. The rich countries will simply pay more for gas. Poor countries cannot. But they must have transportation systems to survive in the modern world. The pegasus unit may prove an unlikely champion for the poor of tomorrow, perhaps even in the United

States if we become more decentralized and self-sufficient as some utopianists desire. Whatever the future holds for us all, we cannot overlook the fact that the pegasus unit costs less to run than gasoline engines.

In 1922 a competition among pegasus powered vehicles took place in France. They used wood charcoal and coal in place of gasoline and had some attraction for the French public. For several years following this event, auto shows regularly included several versions of pegasus powered cars. However, the complicated operation and imperfect functioning of these early models made them unattractive to run. Aside from the lure of cheap fuels they offered little to a transportation hungry public enthralled by the speed and ease of operation promised by the gasoline engine.

### *Germany*

Germany's development of the pegasus unit followed the same pattern throughout the 1920's; aside from the economic advantage of pegasus fuels over gasoline, there was no government subsidy or tax advantage to encourage experimentation and development. From the moment of the National Changeover of 1933, however, Germany's posture forecast war and her experience with the shortages of 1917 turned German scientists and engineers to a study of alternative energy resources. They were well aware of the shortage of petroleum which they would soon face when war was declared and Germany became a fortress under siege. They needed to develop a device which was practical rather than radical in that it had to make their existing gas operated technology, which was well established and widely interdependent, operate on alternative fuels. The ancient pegasus was the logical answer.

In 1935 Germany's ruling political party promoted a national "Test Drive With Domestic Fuels." A preliminary competition had been held in what had been Austria in 1933, and again in 1934 the Austrian Alps played host to the "First International Alpine Test Drive With Alternative Fuels." These tests demonstrated that the pegasus vehicle with skilled handling could negotiate even difficult mountains without breakdown. The German "Test Drive With Domestic Fuels" differed from the other competitions in the substantially longer duration, harsher conditions and systematic evaluation of results. 38 trucks between 4.5 and 13 tons net weight and with pegasus units for coal, lignite, briquettes, charcoal, wood and peat were tested over



distances of 12,000 to 14,000 km, carefully monitored for economy and technical data.

Results of the test showed a high degree of perfection of the pegasus units burning wood and charcoal, whereas coal fired units still suffered developmental shortcomings. Further development was therefore concentrated almost solely on the wood gas pegasus. It was not limited to highway use but most importantly expanded to agricultural uses. The *Reichskuratorium* of agricultural technology carried out systematic experimentation with wood fueled pegasus units and in conjunction with the *Reichsamt Fur Wirtschaftsbausau* (Department for Industrial Growth) promoted development of a standard pegasus for agricultural tractors.

Training of skilled pegasus drivers was assumed by the National-Socialistic Driver Corps through its numerous offices, thereby rendering an important preparation for the future mobilization of the pegasus unit.

The importance of the pegasus for national defense was becoming increasingly recognized, and its development promoted through the German *Wehrmacht*. Following the outbreak of World War II, manufacture and deployment of vehicle pegasus were finally placed under the superintendent of transport (*Bevollmachtigten Fur Kraftfahrwesen*) with the establishment of a special office responsible through a pegasus staff (*Generatorstab*). The role of the vehicle pegasus in the German war effort lay in the liberation of gasoline and diesel fuel for the fighting troops while maintaining transportation at home. This task was served by a relatively low inventory of pegasus vehicles although the front of the *Wehrmacht* already by midyear 1940 stretched from North Cape to Biscay and reached into North Africa. But as enormous areas were conquered in the struggle against Bolchevistic Russia, the pegasus was employed on a larger scale to solve the transport problems extending to the eastern front.

Expansion of pegasus use naturally carried with it expansion of use of pegasus fuels. It became necessary to use coal and lignite fuels besides wood in the units. Since the German soil offered these fuels in almost unlimited supply, German industry sought to develop the means to process these for pegasus use. But it required that the pegasus units be redesigned for these fuels, for which the wood gas pegasus was not suitable.

Coordination of all measures concerned with manufacture and employment of pegasus units of all types was in the hands of the state leadership. Due to the enlarged scope, this entire field was from

midyear 1942 transferred to a special office, the *Central Pegasus Office (Zentralstelle Fur Generatoren)*. This was under the general manager of the 4-year plan and thereby under the authority of the Minister for Armaments and War Production, emphasizing again the importance of pegasus to the war effort. Pegasus had become one of the many weapons of war.

Especially for reasons of war economics, pegasus became more varied and numerous than is evident from observation of vehicles only. Pegasus units liberated liquid fuels in ships of canal and longshore traffic, in locomotives, and in tractors and construction machines.

This many sided use of pegasus demands detailed differentiation of design. At the same time, one of the major tasks of the Central Office was to select those pegasus which had advanced farthest, to bring them to the highest perfection, and then to put them into effective use. Parallel with this went the development of high quality pegasus fuel. A tremendous development and organizational task had to be performed within a short time.

The result was the "stove" of World War II fame. Not many Americans came in contact with them. They were the workhorse of Nazi dominated Europe behind the walls which we were seeking to penetrate. They were a characteristic of Germany's home front effort just as the O.P.A. and "A" Coupons were part of ours. As with our gas rationing at home, the German economy dropped its war time measures as rapidly as possible when hostilities ceased. We wanted to return to normal as quickly as possible, and the Germans wanted to forget the past just as quickly. The "stove" went on the scrap heap along with the debris of war in the first wave of efforts to clean up the damage and rebuild a shattered Europe. The Allies brought gasoline with them when they arrived in Europe and so had little or no use for the curious things that the Germans had used in the face of fuel shortages. By 1973, the devices with which Germany had successfully run her home front while saving her liquid fuels for the battle zones, were relegated to museums and the scraps of literature rescued from *Wehrmacht* files. These petroleum/gasoline substitute systems, or pegasus units as we have seen fit to call them, were an important part of the curriculum at the *Panzertruppenschule*, at Weunsdorf, the equivalent of our Armored School at Fort Knox. Pegasus units were also an important subject in the occupation literature distributed by the provisional civilian governments to the populations of the occupied countries. Whether of the Quisling or Vichy stripe or

of the less infamous varieties, the governments were vastly unpopular. Traces of their directives and manuals for the maintenance of their efforts in behalf of conquering Germany are therefore curios in museums and bear scant reference in native literature.

Under Reichsminister Speer (Hitler's architect and armaments minister and later author of the best seller, *Inside the Third Reich*) preparations for the home front siege had been extremely thorough. Nothing was left to chance. Each kind of device which was to be used for the greater glorification of the Third Reich was tested and improved. Many different types of pegasus units were designed. Most were only hand built to adapt different makes of German cars or trucks to the curious business of running on coal or wood or whatever could be found that would burn fairly well, but two types were actually mass produced in Germany and distributed throughout the axis world. Some American sailors remember seeing these strange looking devices on taxicabs in Japan just after the capitulation. They were also made in France and many American soldiers rode in Parisian taxis which were fueled by pegasus units during the early days of the allied occupation.

Part of the data presented here were salvaged from the German occupation of Denmark. It is amazing how little remained of this technology in view of the important role it had played in securing the Nazi's power. Such is the violent revulsion with which the world wanted to put World War II behind it. Perhaps it is just as well. There are many things that should be forgotten. But there are some obscure bits and curiosities that may serve us well to remember. One such is the pegasus unit.

### *Denmark*

Everyone is familiar with the mileage concept, i.e., the number of miles a given car will go per gallon of gasoline. In most European countries the same concept is expressed in the car's consumption of gasoline (in liters) per 100 km.

In the unfamiliar terms of wood fuel one of the first questions to be asked will certainly refer to the mileage one can expect from wood. Here are some answers.

In the autumn of 1940, a large Copenhagen daily sponsored a performance competition among Danish truck drivers, who at the time were practicing the art of efficient and economic driving on gasoline substitutes. The results were given as consumption per ton-km, or the amount of wood consumed to propel a vehicle

weighing one ton a distance of one kilometer. In practice this is found by measuring the consumption per km of a test vehicle and then dividing by the vehicle weight in tons.

The winner of the competition used an astoundingly low 48 gr per ton-km. The average for the participating truckers was about 100 gr per ton-km. If we translate this latter figure into more familiar terms, one may expect 3 ton-miles per pound of wood. In other words, a three ton truck will travel a mile on one pound of wood. For further comparison, one pound of wood is about a six inch chunk of two-by-four.

Cars will get less favorable mileage than trucks and tractors, but even a performance of one or two ton-miles per pound—a reasonable expectation—will probably strike most people as surprisingly good.

### *Sweden*

The pegasus unit played an important role in the survival of Sweden's economy during the war years. Sweden's experience with the pegasus unit is collected by the Academy of Sciences of Swedish Engineering in a volume entitled "Swedish Experience with Wood-Gas from 1935-1945" published in Stockholm in 1950. This work casts some interesting light on the difficulties faced by Sweden in overcoming the fuel shortage. The adaptation to the pegasus unit was not easily achieved on the broad scale in which it was eventually applied. The Swedes had been familiar with the pegasus unit from about 1850. From that time on, the units were extensively employed throughout the iron industry as they were in most European countries, for heating the furnaces as described above. Sweden's first vehicle pegasus began to appear around 1920. The applications to heavy farm equipment and trucks were far more prevalent than those adapted to automobiles. Since there was no shortage of gasoline, development of efficient pegasus types languished just as it had in the rest of Europe. They were curiosities more often than not. In 1937, there were about 100 pegasus units in all of Sweden. But the approaching war and Sweden's precarious position relative to gasoline supplies in the near future caused Swedish engineers to take another look at the potential of their pegasus units. As in Germany, a central agency supported by the state and organized to expedite the development of gasoline substitute systems was hastily formed. The changeover from gasoline dependency required popularization of the new units and the government stimulated interest by subsidizing companies

which were willing to undertake their manufacture and drivers and mechanics who were willing to learn to handle them. The Swedish Automobile Club contributed greatly to the success of Sweden's national effort by promoting races and competitions between cars, trucks and tractors. The fact that there were more than 75,000 pegasus driven vehicles in use in Sweden by 1945 testifies to the effectiveness of their campaign.

Many different types of pegasus were included in this number. The proliferation of experimental units resulted in marked improvements. The most satisfactory as well as the most interesting pegasus was made by KALLE corporation. It was a compact unit weighing only 45 kg which utilized crushed charcoal in a cross-draft version similar to those described in Chapter VIII below. Most of the variations described in detail here were tried by the *Svedlund, Gragas and Kalle* companies in their pursuit of increased efficiency. There were several areas of difficulty which had to be dealt with in making the first units into practical and easily useable devices. The central problems had to do with clogging the systems with ash and slag. Grates and filters had to be cleaned with water daily. Low tar content in the gas produced was achieved at temperatures above 800°, yet the operational temperatures of the gas fuel had to be decreased to between 300° and 400°C. Elaborate coolers were subject to frequent clogging. The dust and ash produced in the process increased the solid impurities and produced a requirement of frequent oil changes.

There were other difficulties as well. Pegasus units produced large quantities of potentially lethal carbon monoxide. Leaky stacks allowed this toxic element to creep into the closed cabs of various vehicles and sometimes caused "wood-gas sickness." The government enacted many safety regulations specifically for the pegasus unit requiring special handling to avoid this and other dangers inherent in its use. One of the most common types of accident involved fire started by the hearth or by ashes. There was a very significant increase in the number of vehicle fires in Sweden at the height of the pegasus period. Traffic accidents were sometimes blamed on the units which were said to cause drivers to lose consciousness and to drive off the road. All fueling operations were required by law to be performed out of doors. Only specially equipped garages could contain a pegasus unit while it was running. As in most other countries where the pegasus unit was used extensively, they were not well loved. When gasoline was again available, the populous was only too glad to throw them onto the scrap heap.

But Sweden had learned some significant facts for today. Trucks and buses fueled by pegasus units turned out to be more efficient than cars, especially when they were used in long distance hauling requiring few stops. Sweden's agriculture was dependent on its tractors. In 1942 there were several thousand gasoline tractors standing idle for want of fuel. By 1945 there were 15,000 tractors working daily thanks to the pegasus unit. Boats had proven to be a suitable carrier for the installation of the unit, but fuel transport and wetting was a constant agony. The best or most efficient uses to which it was put were fixed or semi-stationary installations. It proved invaluable in saw mills, rock-crushers, pumping stations, etc. It was the key to Sweden's survival in many critical areas and while it may not be remembered fondly in Sweden, manufacturers learned enough about its potential to keep it in the back of their minds.

Volvo was one of the wartime experimenters with the pegasus unit. They were leaders in designing a remote pegasus unit that was towed behind the vehicle it fueled lessening the chances of asphyxiating the driver and/or passengers. Their units also ran on semi-carbonized wood. This pegasus fuel was extremely efficient but quite expensive to produce. The wood was seasoned in a kiln at 250°C which turned the wood brown and reduced its moisture content from 24.5% to 10.5%. The resulting wood fuel produced no soot and maximum heat with no problems in firing the hearth or lengthy starting times from damp or stubborn wood. Volvo has, it was recently reported in a Copenhagen newspaper, complete production plans for a pegasus unit on hand and stands ready to meet a future gasoline emergency with a mass-produced unit available in weeks instead of years.

America lags far behind Europe in experience or readiness to employ these devices in a crisis. Until other dramatic and radical technological devices provide us with ultimately efficient fuels for our vehicles, we will continue to need to know about the pegasus unit. We present here a summary of the historical pegasus unit. It remains for our engineers to take these further along the path of efficiency with all of the improvements new techniques have made possible since 1945. We plan to make a complete set of plans for one of the better units of the past available as soon as possible—possibly within a few months of the publication of this book.

THE PEGASUS UNIT



Pegasus fueled tractor for highway use.



Pegasus fueled farm tractor.



Tractor fueled by wood burning pegasus. Exhaust gas is used for predrying of wood. (90.)



Wood gas fueled barge for river and longshore transport.

Switch engine fueled by wood burning pegasus.

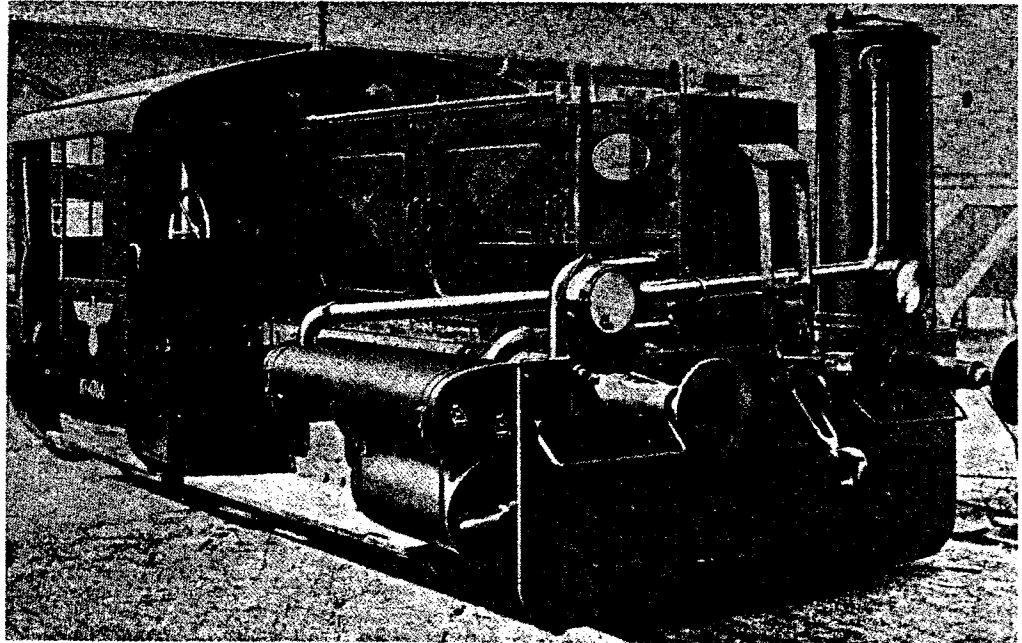



## THE PEGASUS UNIT

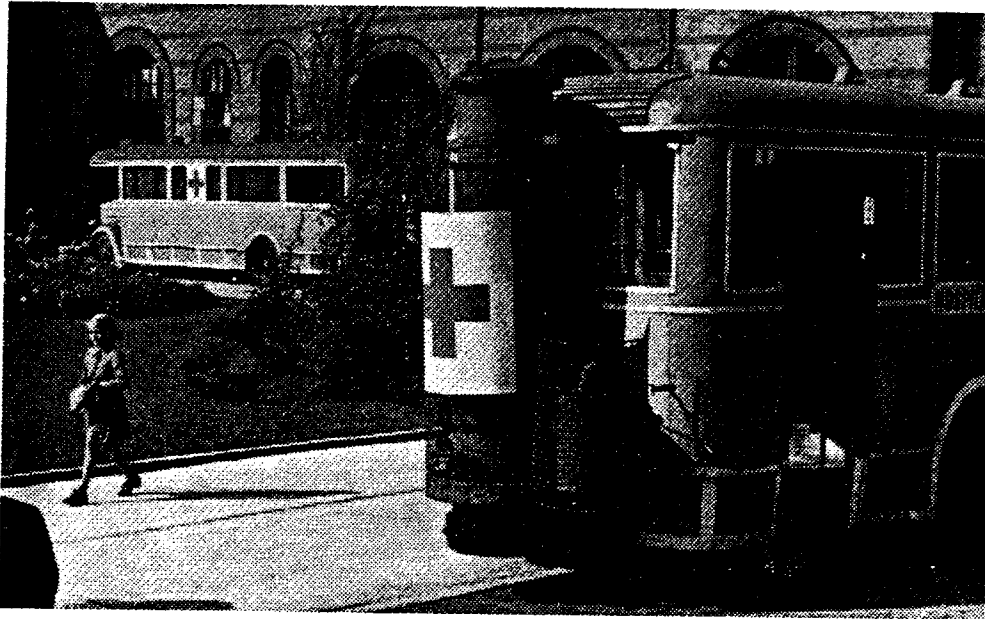

During the German occupation, even emergency vehicles such as this Red Cross bus depended upon the Pegasus Unit to meet national emergencies.

This 1938 Chevrolet carried a Pegasus Unit in place of gasoline in Copenhagen in 1944. Street use in private vehicles was not their primary function, however. Fixed installations and farm machines made more frequent use of them. There were over 75,000 vehicles powered by Pegasus Units in Sweden alone by 1945.

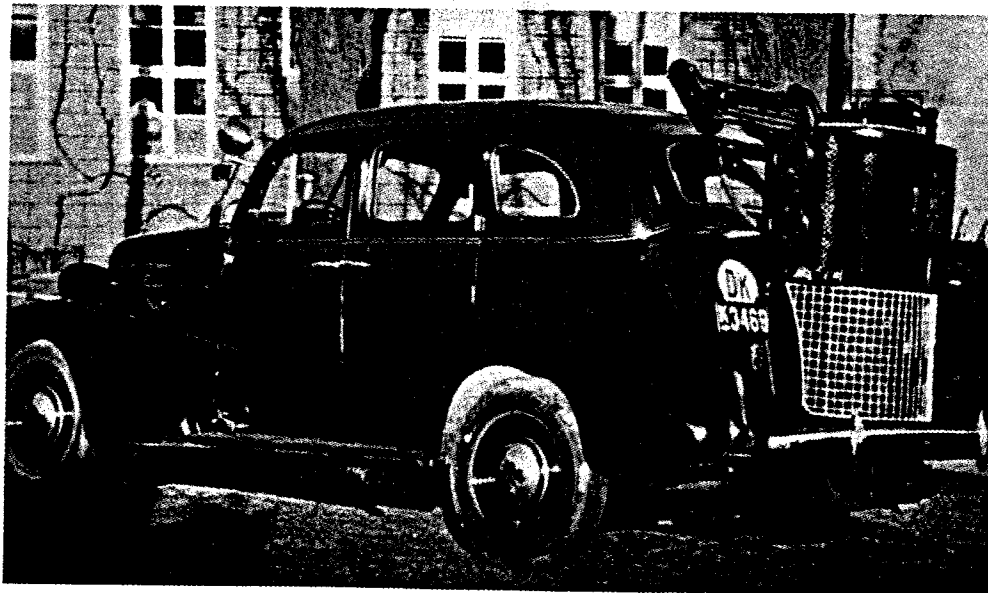

## Chapter II THE LOST ART

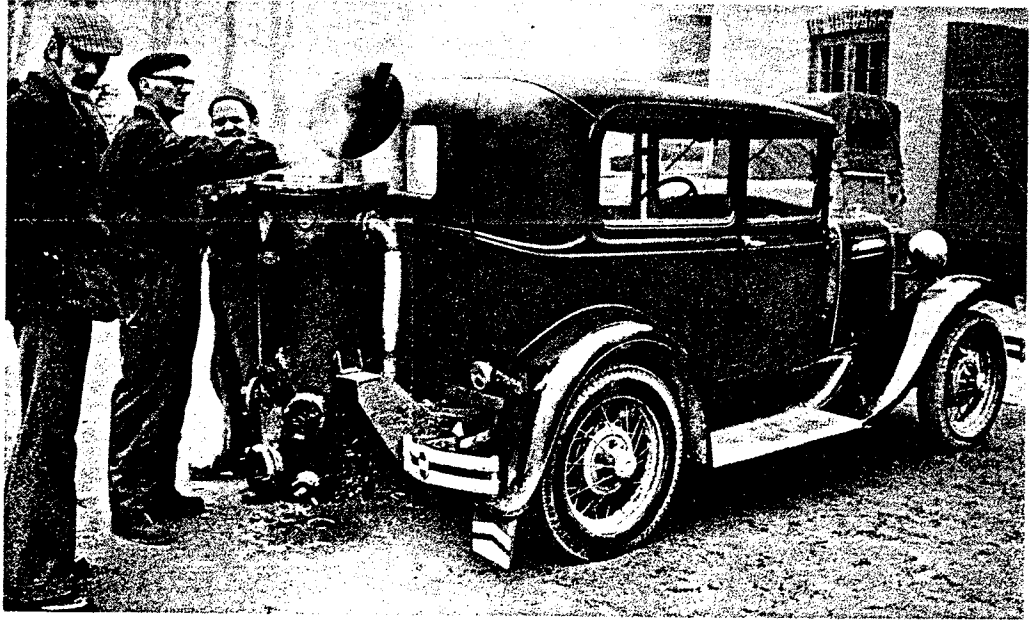

A recent article in a Copenhagen newspaper carried this picture of a revived museum piece being fired up once more. A quickening interest in the almost forgotten Pegasus Unit swept over much of Europe at the time of the Arab embargo in the winter of 1973. These Danes remember the shortages of thirty years ago only too well. They seem to be greeting this reminder of gasoline shortages with somewhat rueful smiles.

## THE PEGASUS UNIT

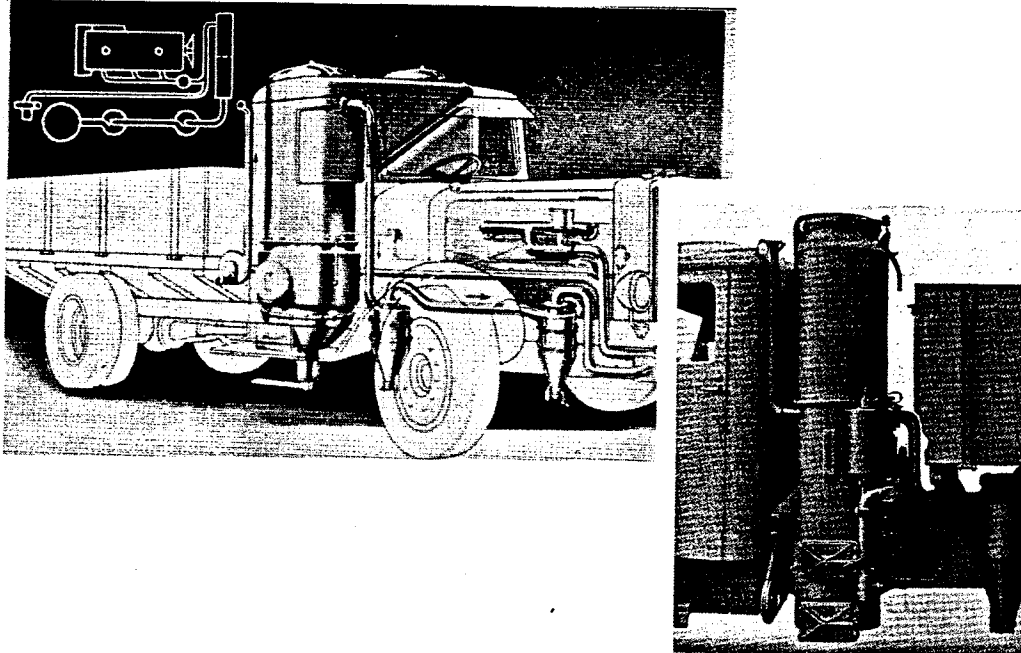
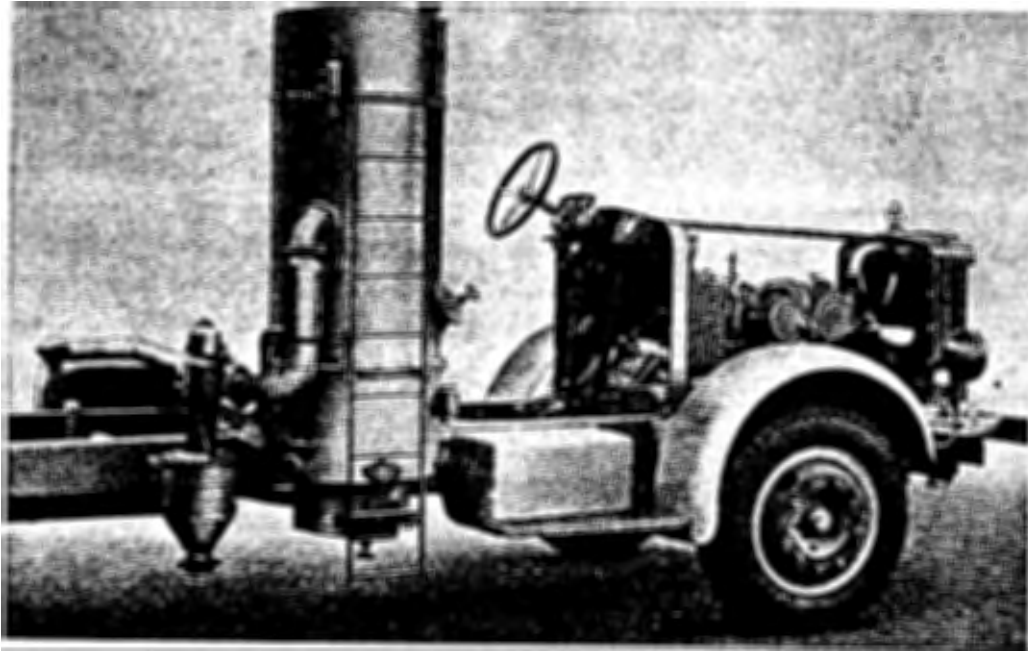

Positioning the Pegasus Unit generally fixed the stack somewhere near the rear of the vehicle. Most trucks carried the stack behind the cab leaving the bed unencumbered. These drawings from a Wehrmacht manual show the installation of a typical heavy truck unit in cutaway view. The hearth is to the rear both to shield the fire box from the wind and to keep the stack with potential carbon-monoxide leaks away from the driver as much as possible. The coolers, however, were positioned in front of the truck radiator, maximizing cool air flow.

## Chapter III

# PRINCIPLES OF SOLID FUEL GASIFICATION

### *GENERAL*

Internal combustion engines run on gas. The liquid fuels used by diesel and gasoline engines are gasified when entering the cylinders, or just before entry. By contrast, solid fuels cannot be simply evaporated into a gaseous state at room temperature. It can be done, however, by using a pegasus unit, and an entire range of solid fuels thereby become useable for internal combustion engines.

The purpose of pegasus gasification then, is to transform solid fuels into gaseous ones and in the process to carry the largest possible amount of energy from the solid to the gaseous state, ideally keeping the gas clean and free from harmful constituents in the solid fuel. Thus a pegasus unit is simultaneously an energy transformer and a filter. In these twin tasks lie its advantages and difficulties.

In addition to their impurities (ash and moisture), solid fuels consist of so-called fixed carbon and volatile matter. The aim of gasification is the most complete transformation of gasifiable constituents into gas so that only ashes and inert materials remain. It is distinguished from degassing or carbonization, which through application of heat expels certain volatilizable parts of the fuel, which is thereby partly changed. Some fluid and gaseous products are created, while combustible charcoal or coke remains, the latter containing the ashes.

When the system is functioning, some carbonization occurs along with gasification, the amount being determined by the nature of the fuel, but as part of the gasification process it is of minor importance. Gasification is a physico-chemical process in which chemical changes occur with the transformation of energy. It therefore follows the laws of chemical reactions, from which for example the type, weight and volume of each pertinent element can be determined in advance. It also transpires according to the principles of energy transformation, particularly the law of conservation of energy, so that a budget can be set up for the energy involved in the transformation.

The same laws are followed by combustion processes, of which gasification is but a special case, and combustion and gasification show many common bases and similarities. The fuels suitable for gasification cover a wide range, from wood and paper to peat, lignite, coal and anthracite, including coal-derived coke. All are chiefly composed of carbon, see Fig. 1, with which come varying amounts of hydrogen, oxygen, and impurities such as sulphur and

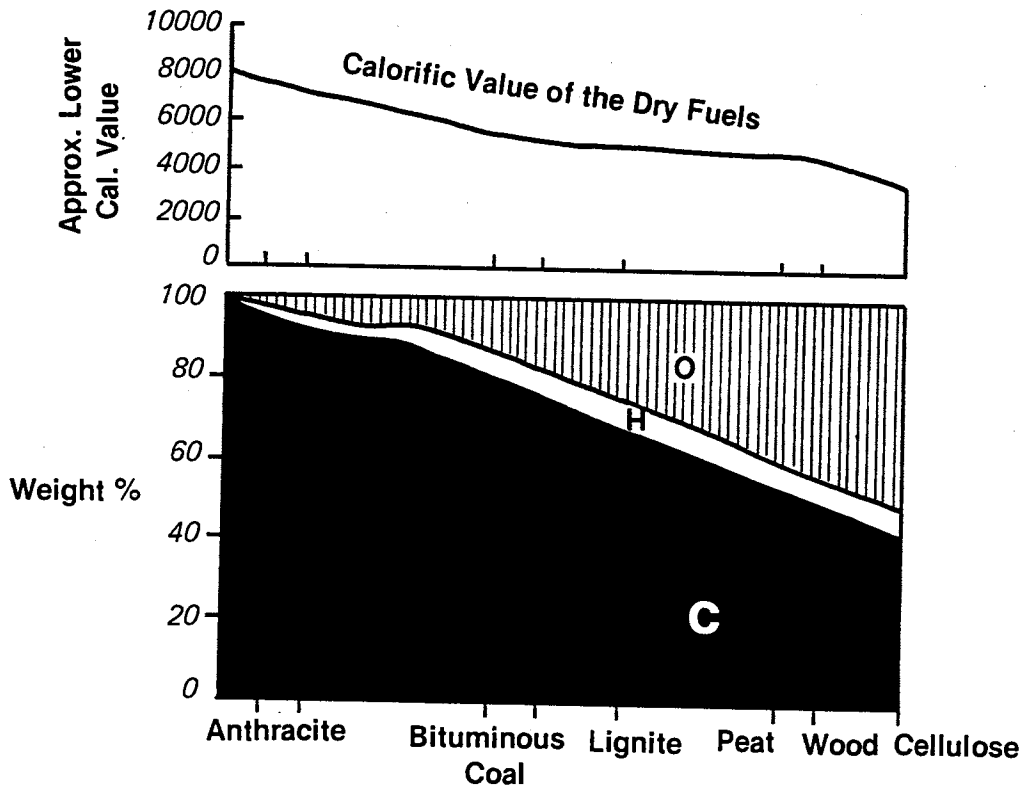

FIG. 1 COMPARISON OF NATURAL FUELS

ashes.

Gasification occurs when air is led across the glowing hot gasification material, the airstream being either dry or containing steam. In the vehicle pegasus and in many fixed installations, the suction effect of the engine's pistons is used for this purpose. This gave rise to the name "suction gas" in the development of gas generators in the first part of this century. The chemical reactions occur between the gasification material and the air, and the product of these reactions is the pegasus gas, while the non-gasifiable part of the gasification material remains as ashes or slag. Most of the energy which is chemically bound in the fuel now is chemically bound in the gas, whereas a minor part of it is noticeable as sensible heat in the fuel, in the gas and in the pegasus body.

Gasification encompasses other distinct reactions which occur concurrently or consecutively. The gas which is the end product of these reactions is strongly influenced by the gasification conditions in regard to its type and quality. The factors influencing the reactions have been extensively investigated through experimentation. The processes in the practical functioning of a pegasus unit differ rather profoundly from the reactions to be expected from chemical equations. The reasons are listed in Chapter III under *Processes in the Stack*.

It may appear superfluous to delve into the theoretical basis of gasification, in view of these unavoidable discrepancies, particularly since one can operate a pegasus unit without such knowledge. When in the following sections the basic principles of gasification nevertheless are explored, it is primarily because a knowledge of principles facilitates evaluation of certain otherwise baffling phenomena and alleviation of operational difficulties.

#### AIR GAS (SEMI-COMBUSTION)

When air passes over glowing carbon, combustion will occur. This constitutes a swift combining of carbon with the air's oxygen, so-called oxidation. If insufficient air is at hand to burn the carbon totally, then incomplete or semi-combustion occurs. It occurs in some measure in all combustion processes due to local oxygen deficiencies, thus also in the engine, and it is counteracted by a generous air flow (air excess).

However, for air gasification, conditions promoting semi-combustion are deliberately created. The product of air gasification is combustible carbon monoxide. The semi-combustion follows the chemical equation:

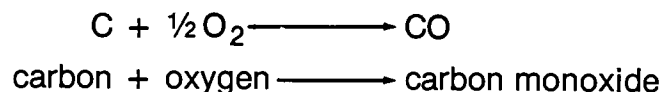

In the pegasus unit the oxygen is provided by the air stream. It is derived from the well-known composition of dry air of 21 parts oxygen and 79 parts nitrogen by volume, and hence a nitrogen

volume of  $79 \div 21 = 3.76$  times the oxygen volume is involved. It is therefore well to consider not only the oxygen part of the gasification air stream but also the nitrogen part.

To be sure, this is important in all combustion processes. Without nitrogen extremely high temperatures would ensue and the process would be difficult to control, but nitrogen is also an undesired and unpleasant element in the gasification process. Nitrogen is inert, and it thereby effectively dilutes the gas and lowers its heating value. Because of the bloated volume of the nitrogen rich gas, the pegasus' pipes, filters and coolers must be correspondingly large. Moreover, heat is consumed in raising the temperature of the nitrogen to that of the gasification process, and this appears as a loss in the heat budget of the process.

To present a picture of the size relationships in air gasification, the nitrogen which passes unchanged through the process will be included in what follows, rather than using the conventional method of depicting gasification in chemical equations. Table 1 shows the volume and weight relationships as well as the heat budget for the theoretical case of gasification without heat loss. In this the reader may examine the most important characteristics of this gasification method.

Table 1: Fuel Budget in Semi-Combustion

Material Budget							
1	Reaction	C	+ ½O <sub>2</sub>	(+ $\frac{3.76}{2}$ N <sub>2</sub> )	→ CO	(+ $\frac{3.76}{2}$ N <sub>2</sub> )	
2	Weight per mole	12	+ 16	(+ 51)	→ 28	(+ 51)	kg
3	Gas produced	by volume	—	11.2	(+ 42)	→ 22.4	(+ 42) Nm <sup>3</sup> per kmole
4		in %	—	21	79	→ 35	65 volume %
5		per kg C	*	+ 0.93	+ 3.5	→ 1.87	+ 3.5 Nm <sup>3</sup>
6		per kg C	*		+ 4.43 dry air	→	5.37 air gas Nm <sup>3</sup>
			(1 kg.)				
Heat Budget							
		Energy Input			Energy Output in the gas free		
7	in kcal/kmole	97,000	0	0	67,700	0	29,300
8	in %	100	0	0	70	0	30

From this, the heating value of—

$$\begin{aligned} \text{Carbon: } & 97000 \div 12 = 8080 \text{ kcal/kg} \\ \text{Carbon Monoxide: } & 67700 \div 28 = 2420 \text{ kcal/kg} \\ & \text{or } 67700 \div 22.4 = 3020 \text{ kcal/Nm}^3 \\ \text{Air gas: } & 0.35 \times 3020 = 1060 \text{ kcal/Nm}^3 \\ \text{Free heat: } & 29300 \div 12 = 2440 \text{ kcal per kg C.} \end{aligned}$$

\* 1 kg carbon (C) is not to be equated with 1 kg fuel. Due to inert constituents in fuel, more than 1 kg is needed to yield 1 kg carbon. For example, 1.1 kg anthracite, 1.8 kg lignite briquettes, or 2 kg wood.

Direct air gasification is thus inefficient because of the free heat generated which has no further use in this process, and because of the relatively low heating value of the air gas, resulting from the dilution by nitrogen. Complete combustion with subsequent dissociation of the carbon dioxide is theoretically more efficient.

Complete combustion represents an extreme case of air gasification and an undesirable one, for as such, it delivers a gas without calorific value, the combustion product being a mixture of carbon dioxide and nitrogen, and non-combustible. Complete combustion or oxidation of the carbon occurs thus:



respectively with inclusion of atmospheric nitrogen as:

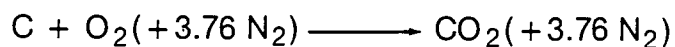

This is strongly exothermic (heat producing) reaction. From Table 1 the following values can be derived: 1 kg carbon burns with 8.87 Nm<sup>3</sup> air to 8.87 smoke. This consists of 21% (by volume) carbon dioxide and 79% nitrogen. Thereby heat is generated in the amount of 8080 kcal, i.e. the total calorific combustion has zero efficiency. In pegasus operation, at least some complete combustion must take place in order to begin the gasification process, heating the fuel via the free heat generated, which is required for the subsequent gasification processes.

However, in the presence of glowing carbon, complete combustion cannot take place, because at high temperatures the CO<sub>2</sub> will immediately be reduced to carbon monoxide:

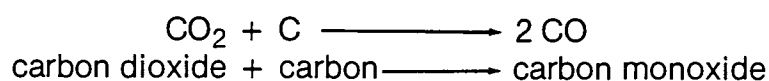



So the  $\text{CO}_2$  is decomposed as it dissociates. The extent of this dissociation depends on the temperature prevailing. Temperature ranges from  $400^\circ$  to  $1000^\circ$  are portrayed in Fig. 3. The graph indicates that dissociation commences at about  $400^\circ$  and that about 25% dissociation takes place at  $600^\circ$ ; with almost complete dissociation at  $1000^\circ$ . In other words, the higher the temperature, the more complete the dissociation. At total conversion, two unit volumes of CO are created for each unit volume of  $\text{CO}_2$ .

Dissociation of  $\text{CO}_2$  is an endothermic (heat consuming) process by which 1720 kcal per  $\text{Nm}^3$  are consumed, proportionally less at partial conversion. This heat consumption must be covered by the glowing fuel in the pegasus. As  $\text{CO}_2$  dissociation proceeds, the temperature in the combustion zone will accordingly drop and with it the extent of dissociation. It results in a reversal of the reaction as:



i.e. dissociation of the CO into carbon (soot) and carbon dioxide. Heat is thereby generated in the amount of 860 kcal/ $\text{Nm}^3$ .

The process can thus go both ways:

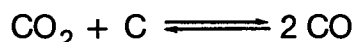

The direction of the reaction depends on the temperature regime. At rising temperature it will occur in the direction of CO, at falling temperature toward  $\text{CO}_2$ .

Reversible processes of this type are called chemical equilibria. In this case equilibrium must be reached between solid carbon and gaseous carbon monoxide and dioxide.

The reactions can also occur when glowing carbon is not present, but then much higher temperatures are required. For example, to attain the 25% dissociation which in Fig. 2 occurs at  $600^\circ$  would require  $2300^\circ$  in the absence of carbon. The glowing carbon thus acts as a catalyst.

In the present case  $\text{CO}_2$  will dissociate at a given hearth temperature until the proportion  $\text{CO}_2:\text{CO}$  corresponds to that temperature. When this condition is reached, all reactions cease, as equilibrium has been reached. If at this point the pegasus hearth temperature is raised by increasing the air flow with ensuing increased combustion, the CO producing reactions will again commence until a new equilibrium is reached.

The equilibrium conditions shown in Fig. 2 were attained after very long reaction time. In the actual installation, particularly at full gas production and the correspondingly high air flow, substan-

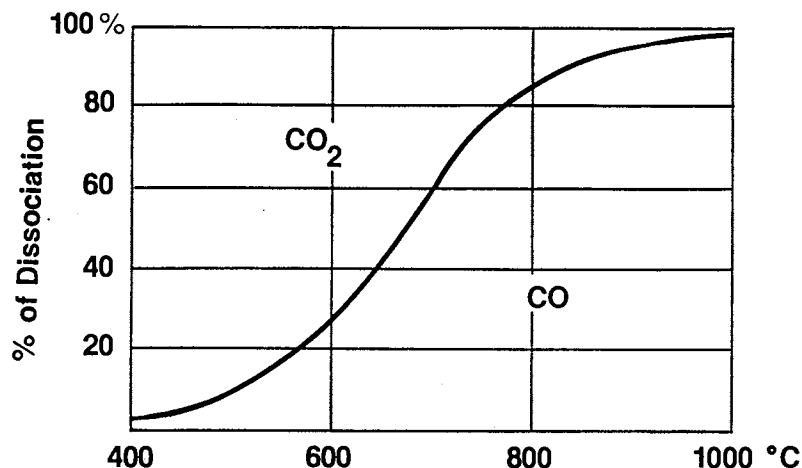

FIG. 2 DISSOCIATION OF  $\text{CO}_2$  IN PRESENCE OF C AT HIGH TEMPERATURES AND ATMOSPHERIC PRESSURE

tially shorter reaction time is available. Successful functioning of a pegasus unit therefore depends on whether the feed and responsiveness of the fuel will permit a sufficiently high reaction speed, so that the reactions can reach equilibrium or near-equilibrium to maximize CO production despite the time limitation.

If the fuel's response capacity is insufficient the reactions will produce a less favorable relationship  $\text{CO}_2:\text{CO}$ , i.e. the calorific value of the gas will be lowered.

It is clear from this how important the role played by the fuel's responsiveness is in the gasification process, and that the calorific value of the gas depends on it. Full responsiveness depends on the physical state of the fuel, surface roughness, surface-to-volume ratio and porosity, among other things (see Chapter V). This may be explained by the necessity of having gas enter into close contact with the solid fuel in the gasification process.

Due to the temperature dependent  $\text{CO}_2$  dissociation, the composition of the air gas is also temperature dependent. This is shown in Fig. 4. It may be seen from this that below  $400^\circ$  only inert smoke can be produced. The CO production commences above this temperature, increases with rising temperature and reaches at  $950^\circ$  about the 35% value corresponding to the air gas in Table 1. A minor proportion of  $\text{CO}_2$  is still in evidence, though, even at high temperatures. Depending on the CO content, the calorific value of the gas rises from zero to the value of the air gas, about  $1060 \text{ kcal/Nm}^3$ . Fig. 3 shows readily that the gas calorific value would

encourage operation of the pegasus at the highest possible temperatures, a rule which is sound for other reasons as well.

Some researchers have questioned whether the creation of CO occurs through dissociation of CO<sub>2</sub> and have proposed that direct creation of CO may take place from semi-combustion. This is a moot question, however, and of no importance for the practical exploitation of the gasification process.

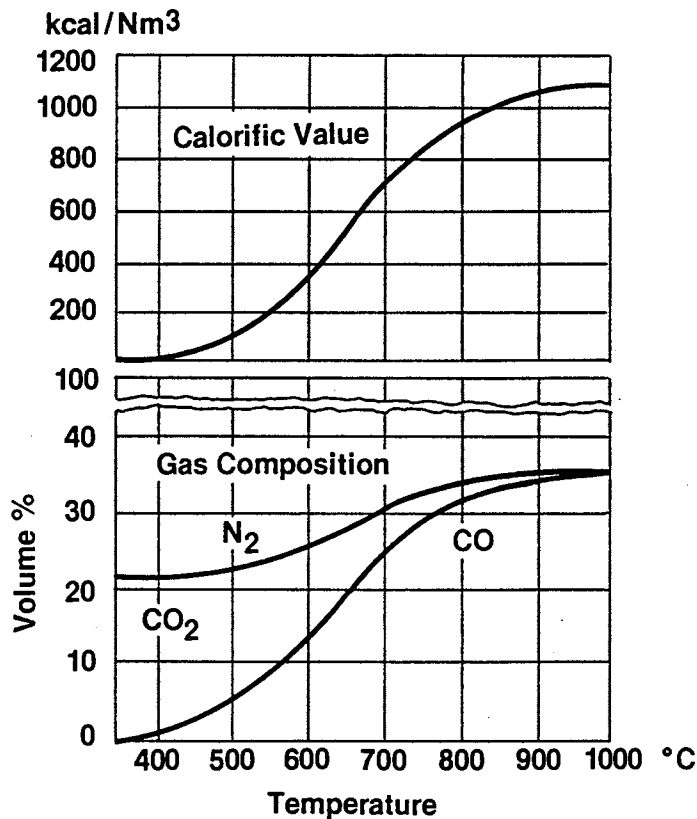
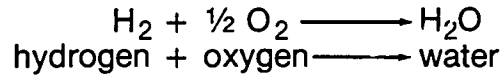

FIG. 3: COMPOSITION AND CALORIFIC VALUE OF AIR GAS IN THE TEMPERATURE RANGE BETWEEN 400° AND 1000°

*MIXED GAS*

Gasification in the pegasus occurs continuously under the influence of steam, as the air flow always contains some moisture. To this must be added in most gasification processes the natural moisture content of the fuel. In addition, almost all fuels contain some chemically bound hydrogen, depending in amount on the chemical composition of the fuel, and this will react in the hearth zone as:



creating steam which is incorporated into the gas.

For these reasons, air gasification must be viewed as mixed gasification. If steam is added in predetermined quantities to the air stream in order to keep the hearth temperature low and create more favorable slag conditions, then so-called mixed gas production takes place.

### STEAM DISSOCIATION

At the temperatures found in the hearth zone, water exists only in the vaporous state. For gasification it must be dissociated. Only then can its components enter into the reactions, hydrogen (H<sub>2</sub>) becoming available as a combustible constituent of the generated gas, and oxygen (O) being freed for oxidation of the carbon. Since dissociation is an endothermic process, the participation of steam in the gasification process will tend to depress the temperatures. On the other hand, a possibility is provided to utilize the free heat of the gasification by adding steam to the gasification process.

If steam enters into contact with the glowing hot coal, it will dissociate thus—

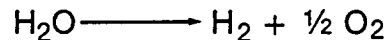

Hereby 1 Nm<sup>3</sup> of steam will produce 1 Nm<sup>3</sup> H<sub>2</sub> and 0.5 Nm<sup>3</sup> O<sub>2</sub>. But different amounts of heat are required when liquid water is used rather than steam. Dissociation of 1 Nm<sup>3</sup> of steam requires 2570 kcal, whereas dissociation of the corresponding quantity of liquid water takes 3050 kcal, since the heat necessary to convert the liquid water to steam must be added.

The dissociation of steam proceeds similarly to CO<sub>2</sub> dissociation, being temperature dependent and increased by high temperatures. Fig. 4 illustrates the degree of dissociation of steam in the presence of carbon at temperatures ranging from 400° to 1000°. Research has been conducted internationally to increase the thermal efficiency of solid fuel through gasification, using the dissociation principle.\*

If water or steam is introduced in the air gas production process, it can only dissociate to the extent that free heat is liberated in the gasification. Theoretically, the most advantageous ratios

\* See O.E.E.C. publication PRA/CR/WP3(53)1.

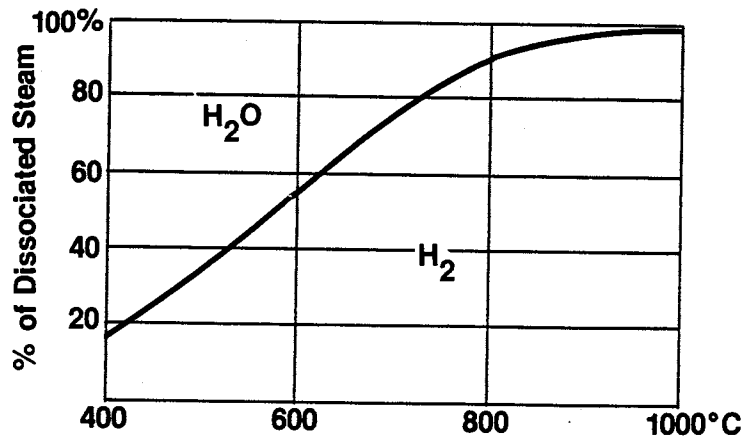

FIG. 4: DISSOCIATION OF STEAM IN THE PRESENCE OF GLOWING CARBON

attainable in the mixed gas among the combustible components are as follows:

Using liquid water:

1 volume  $H_2$  to 2.34 volumes CO or  
0.43 volume  $H_2$  to 1 volume CO

Using steam:

1 volume  $H_2$  to 1.96 volumes CO or  
0.51 volume  $H_2$  to 1 volume CO

From this we may compute the most advantageous composition of the mixed gas by volume and using liquid water:

40% CO + 17%  $H_2$  + 43%  $N_2$  = 100% Mixed Gas

It can be seen that with a calorific value of 3050 kcal/Nm<sup>3</sup> for the hydrogen, the calorific value of the gas is increased from 1730 kcal/Nm<sup>3</sup> to 1865 kcal/Nm<sup>3</sup> by use of steam and by altering the gas composition somewhat. Compared with the theoretical air gas without the addition of water, see Table 1, the combustible component is now raised from 35% to 57% by volume, and the energy content from 1060 to 1765 kcal/Nm<sup>3</sup>, an increase of 64%. The advantage of water addition is thus clearly demonstrated in regard to calorific value of the air gas.

*Combustion of Carbon with Dissociated Steam*

When H<sub>2</sub>O is dissociated in the presence of glowing carbon, the oxygen fraction may directly oxidize the carbon, so that combustion results. However, heat is not generated as in normal combustion, rather, it must be added.

At low temperatures, complete combustion occurs as follows:

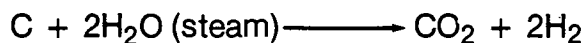

This reaction generates 1 unit volume of CO<sub>2</sub> and 2 unit volumes of H<sub>2</sub> from 1 unit volume of H<sub>2</sub>O. This utilizes about 18,000 kcal/kmol, or about 1500 kcal/kg C, but the gas shows here a 67% combustible fraction and an energy content of 2040 kcal/Nm<sup>3</sup>.

Even more favorable in this regard is the semi-combustion of the carbon:

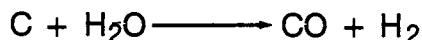

This reaction occurs at higher temperatures. It requires a heat consumption of some 28,000 kcal/kmol, respectively some 2350 kcal/kg C. From 1 Nm<sup>3</sup> steam it will produce 1 Nm<sup>3</sup>/CO and 1Nm<sup>3</sup>/H<sub>2</sub>, i.e. a 100% combustible gas. The energy content of this water gas is 2790 kcal/Nm<sup>3</sup>. It was previously shown that by total utilization of the heat available in the hearth a maximum of 57% combustible gas components could be achieved. In order to raise this result to the 67% or even the 100% discussed above, heat must be provided beyond what is generated in the hearth zone. To obtain the 100% combustible gas above, 40% additional heat must be provided. Operation can also take place as intermittent combustion in the hearth zone, alternating with water dissociation, but neither imported heat nor alternating operation can be considered for the vehicle pegasus. Consequently, the reactions described above can only take place to a modest extent limited by the available heat.

The above reactions have the distinct advantage of being unencumbered by nitrogen, and hence do not produce a diluted gas. A further advantage is gained from the cooling effect of the water which minimizes difficulties from slag formation.

*The Gasification Diagram*

As shown, a wide variety of gasification reactions can occur in the hearth zone, from complete combustion of the carbon into

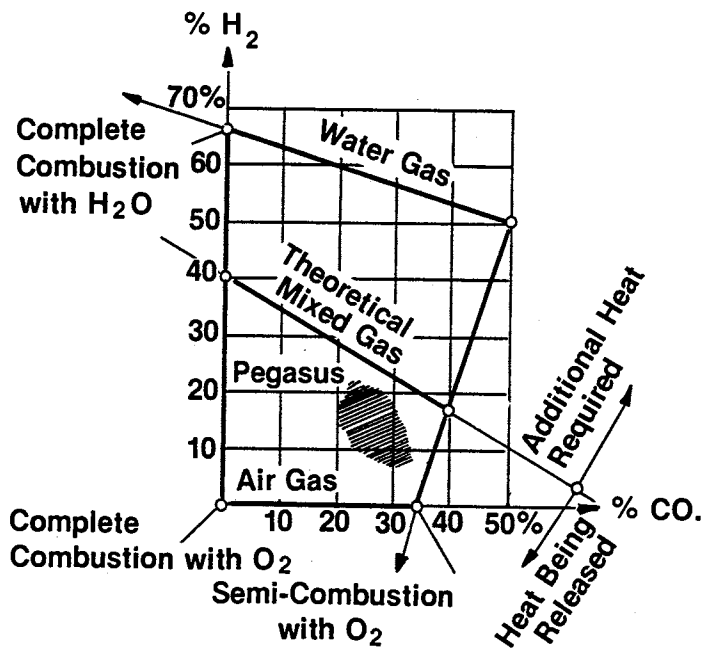

Fig. 5a Combustible Constituents by Volume

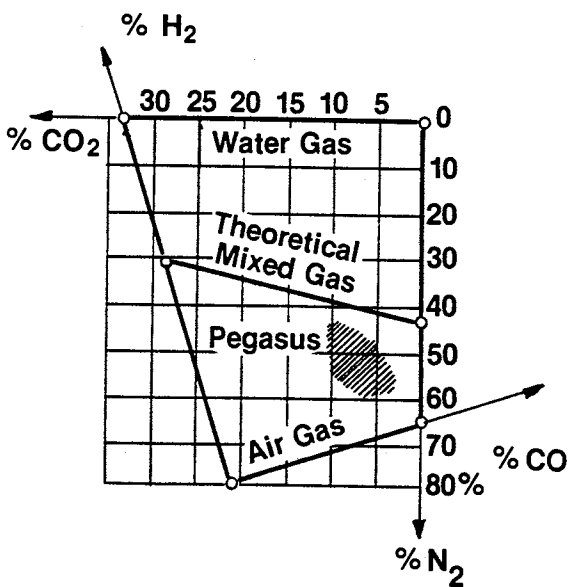

Fig. 5b Incombustible Constituents of the Pegasus Gas by Volume

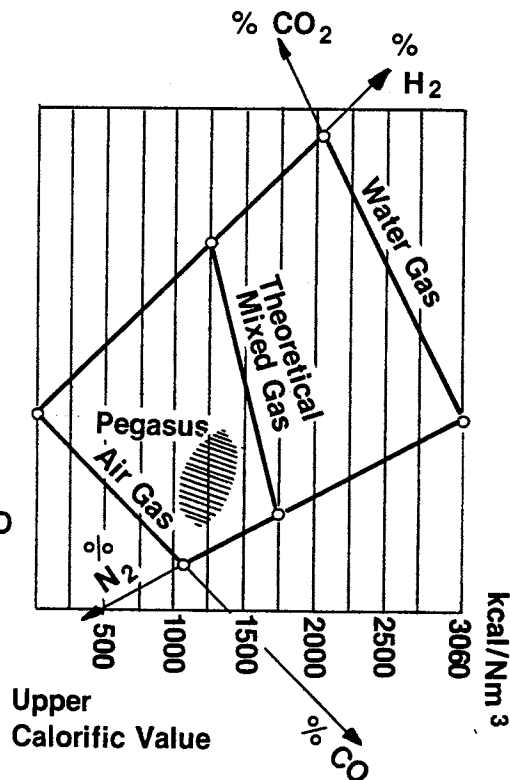

Fig. 5c Calorific Value of Pegasus Gas

FIG. 5: CALORIFIC VALUE OF THE PEGASUS GAS

smoke without energy content, to semi-combustion of the carbon with water, resulting in water gas composed entirely of combustible constituents. In between lie numerous possibilities of gas production, depending on the gasification conditions. They have all been condensed with display of the important parameters in the gasification diagram shown in Fig. 5.

The sides of the gasification diagrams represent the volumes of the four gases CO, H<sub>2</sub>, CO<sub>2</sub> and N<sub>2</sub> of which pegasus gas is chiefly composed. The sides of the diagram simultaneously indicate the four limiting cases which are reachable by perfect, no-loss gasification. The corners show the four possible types of combustion of carbon. Within the diagram lie the achievable gasification cases, somewhat apart from the ideal cases. Fig. 5a presents the combustible gas components CO and H<sub>2</sub> in percentages of volume. At the bottom is the air gas area. Above lies the area of the mixed gas, containing more or less hydrogen. The top line represents the water gas. From the volume percentages of CO and H<sub>2</sub> can be determined the location in the diagram of any given pegasus gas, as well as the possibility of achieving more favorable gas composition in the given case by alteration of the gasification conditions. The area in which the vehicle pegasus is located is likewise indicated in Fig. 5. It covers but a small fraction of the field and stays below the line for the theoretical mixed gas, which requires all of the heat from the hearth for H<sub>2</sub>O dissociation. Consequently, the gas from the pegasus will always show some sensible heat, although less with gas rich in combustible constituents.

In Fig. 5b the Gasification Diagram is calibrated to show the non-combustible constituents of the gas. The operating region of the vehicle pegasus is also shown in this diagram. It should be noted that its gas contains from 3% to 10% CO<sub>2</sub> and 45% to 60% N<sub>2</sub>.

In Fig. 5c a scale has been superimposed on the diagram to show the calorific value of the gas when the combustible constituents are known. The vehicle pegasus operating range within the diagram falls between 1100 and 1500 kcal/Nm<sup>3</sup>.

The delineation of the area in which the gas composition places the vehicle pegasus should not be interpreted to mean that the gasification only occurs within the indicated limits. The area merely shows where a particular fuel and the result of gasification are to be located. Gasification processes localized in time and space may occur anywhere in the diagram, but the phenomena are quantitatively minor and do not displace the area of the composite end result.



## Chapter IV

# FUNCTIONING OF THE PEGASUS UNIT

### *Processes in the Stack*

When motor vehicles are operated with pegasus systems, gasification is achieved with solid fuel material such as wood, paper, peat, charcoal, anthracite, lignite, etc. The generated gas is led to the engine after being mixed with air in the carburetor. The air-gas mixture is compressed and ignited by the spark from the spark plug just as is a gasoline-air mixture.

Several processes are available for gasification of the solid fuel, but none exclusively predominates in the vehicle pegasus, due to the conditions under which it must operate. Moreover, several reactions occur simultaneously and continually, governed by the temperature of the hearth zone, responsiveness of the fuel, moisture content of the air and so forth. The outcome therefore is a mixture which draws its components from the reactions involved. It is the purpose of the pegasus design to influence the reactions in such a way that a given fuel will yield a gas that burns in the engine with good performance and ample speed.

This is difficult to fulfill in a practical way, since opposing reactions, fuel characteristics and operating conditions rarely can be harmonized toward maximum results. Hence, gasification in the vehicle pegasus is always a compromise solution and should be judged as such. It is desirable to produce a gas rich in combustible components. This primary demand calls for a precisely adjusted air flow to the hearth, avoiding excess air, as the excess oxygen otherwise leads to  $\text{CO}_2$ , which will dilute the gas.

It is for the same reason advantageous to suppress the air gas production in favor of the water gas reaction. By high temperature air gasification the CO fraction will increase, but only when little or no steam is present, as otherwise the temperature will be depressed and the  $\text{CO}:\text{CO}_2$  ratio unfavorably affected. At the same time, hot gasification promotes slag deposition and wear on the stack.

Moisture in the fuel and in the air will unavoidably keep the gasification reactions in the mixed gas area, due to the water gas reaction.  $\text{CO}$ ,  $\text{H}_2$ ,  $\text{CO}_2$  and  $\text{H}_2\text{O}$  (steam) are active in this reaction, but not the diluting nitrogen. The water gas reaction represents one of the most important relationships between these gases, tying them into the equilibrium state, as described earlier. In contrast, the  $\text{CO}_2/\text{CO}$  equilibrium of air gasification is seldom reached under the working conditions of the vehicle pegasus. It requires more time, as

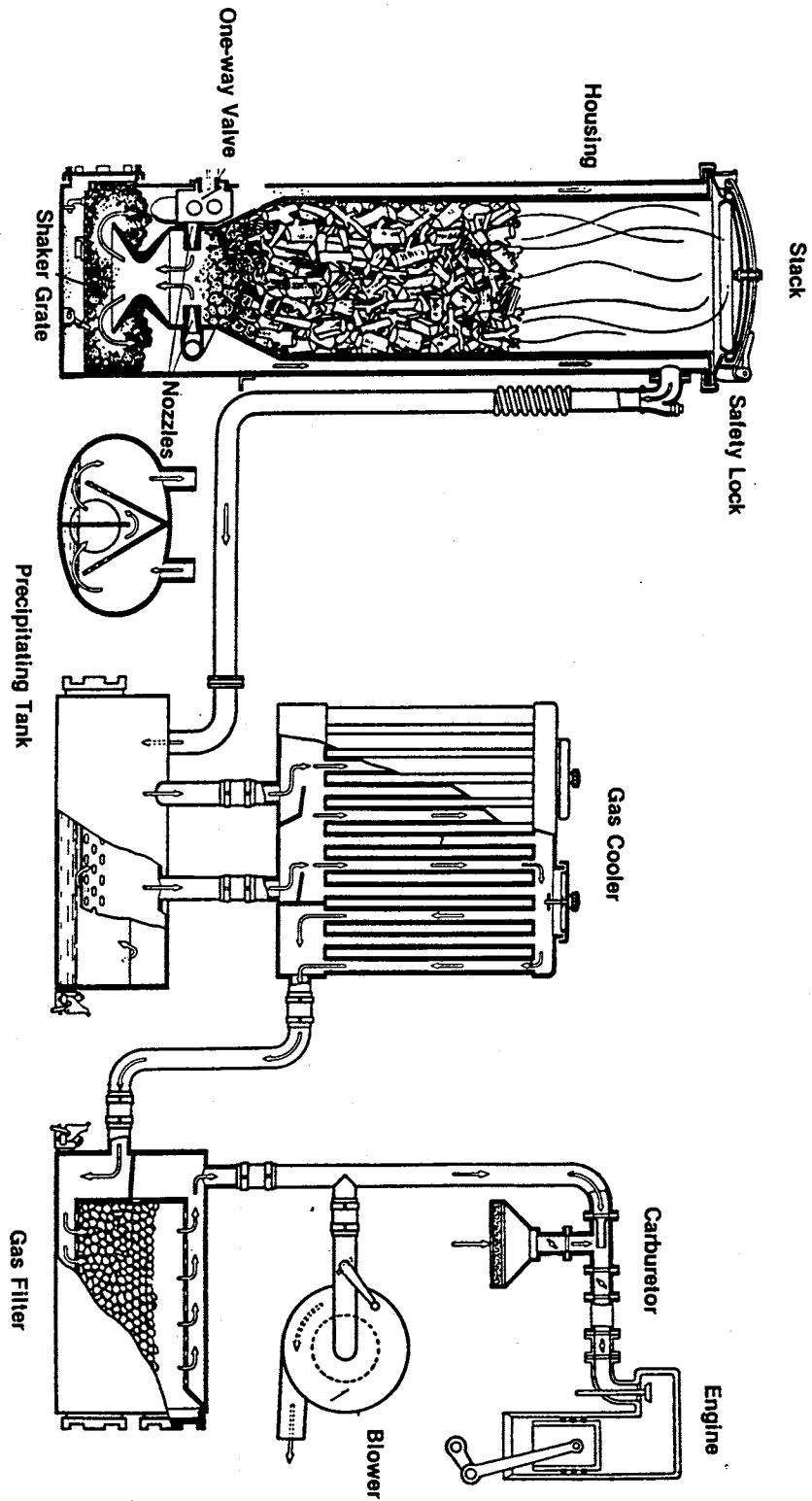

FIG. 6: SCHEMATIC VIEW OF DOWNDRAFT PEGASUS

the gases (CO and CO<sub>2</sub>) must react with solid carbon, and also because the surface condition of the fuel can retard the reaction.

The course of the gasification reactions is thus strongly affected by the type of fuel and its condition in the hearth zone. Before considering these relationships in detail, let us observe the air-gas flow through the system.

Fig. 6 provides a schematic view of a typical vehicle pegasus of the downdraft type.

From a one-way inlet valve air is drawn through the hearth zone by the startup blower before the engine is started. After the engine is started, the air stream is maintained by suction from the manifold. Gasification occurs in the hearth zone and the gas is sucked by the engine through the exit pipe from the stack into the gas cooler. Here the gas is cooled and coarse dust filtered off.

From the cooler the gas is led through the filter apparatus and cleansed of remaining dust. From the filter the gas goes to the carburetor where it is mixed with air in ratio between 1:1 and 1:1.1, arriving in the engine as a gas-air mixture. In the engine's combustion chambers, the gas-air mixture is compressed and brought to ignition by the sparks in the spark plugs exactly like the well-known gasoline-air mixture.

It is now useful to look in more detail at what transpires in the stack. First, the fuel is heated and subjected to degassing prior to gasification of the carbon. The high hearth temperature causes the fuel to be transformed into solid, liquid and gaseous products, depending on temperature and air control (the generator is closed air-tight). The proportions of these products depend on the pressure and on the temperature in the hearth zone. According to the nature of the fuel, combustion products are formed which are solid, such as charcoal and coke; liquid such as acids and tars; and gases such as carbon dioxide, carbon monoxide, hydrogen, methane and other hydrocarbons.

Fig. 6 shows the stack filled with wood fuel when the system is operating.

The heat radiating upward from the hearth carbonizes the fuel directly above. Charcoal is produced continuously, descending into the hearth zone.

This carbonization process produces carbonization gases which likewise are drawn through the glowing charcoal in the hearth below. This causes the steam in the carbonization gases partly to dissociate into hydrogen and oxygen. Tar components are also

dissociated. The dissociated oxygen burns with the charcoal and the hydrogen remains in the gas, aiding its eventual ignition.

Additionally, steam and water condensate will form higher in the stack at temperatures from 170° to 200°. From 300° to 500° formation of the oxygen gases CO<sub>2</sub> and CO will occur as well as heavy hydrocarbons. Degassing and distillation will at these temperatures produce H<sub>2</sub>O, C<sub>2</sub>H<sub>4</sub>O<sub>2</sub> (vinegaric acid), CH<sub>3</sub>OH (methyl alcohol) and light tars: C<sub>n</sub>H<sub>m</sub>. These condensates are harmful to the engine, and since the engine burns only gas, the condensates represent energy losses.

At temperatures above 500° the production of heavy hydrocarbons drops off while carbon monoxide and hydrogen compounds increase. Distillation decreases. Above 700° there is strong hydrogen formation and the heavy hydrocarbons decline further. In particular, there is no tar formation above 700°. The combustible distillation components now appear as combustible gas and can be burned in the engine. From this an important fact can be derived: the hearth temperature should never be below 700°-900°. At lower temperatures tar formation takes place and the distillates are largely useless. Moreover, the heavy hydrocarbons cannot dissociate and gas production will deteriorate.

Thus, operation must be arranged to keep the hearth temperature continually above 700°-900°. This means that driving should be done at high r.p.m. with the throttle fully open.

Assuming now that the hearth temperature is adequate, the carbon will gasify, solid carbon such as charcoal or coke becoming transformed into combustible gas. The oxygen entering the hearth zone in the air stream reacts with the carbon to form carbon dioxide, releasing heat. When the hearth temperature is high enough, the oxygen in the carbon dioxide will be reduced, and carbon monoxide is formed. This is the most important of the combustible gases, and its formation is closely tied to the temperature.

When the hearth temperature is below 700° the oxygen reduction is appreciably less, so that the necessity of keeping the engine loading and the r.p.m. continually high again is obvious, since this will keep the temperature above 700°-900°.

The following reactions occur in the stack both sequentially and simultaneously. First, oxidation of the carbon:



Hereby carbon dioxide is formed. There is also some partial

combustion in the absence of sufficient oxygen:



At high temperatures steam will dissociate in the presence of carbon:



At intermediate temperatures, further steam reaction will occur:

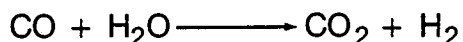

Further reduction of the carbon dioxide will follow in the presence of high temperature carbon:



In other words, the air enters the stack and is led to the hearth through the air nozzles. The hot charcoal near the nozzles burns to carbon dioxide. Being sucked through the hot charcoal below, the non-combustible carbon dioxide is reduced to carbon monoxide.

### *Calorific Value Transfer*

By combustion of the various fuels, considerable quantities of energy are liberated as heat. In order to be able to compare these liberated heat quantities, they are referred to weight units in the case of solids and to volume units in the case of gases. In the terminology of this book these heat quantities will be identified as the calorific value of the fuel. Another common term is "heat of combustion".

By calorific value we mean the number of heat units or calories generated by combustion of 1 Nm<sup>3</sup> of gas. The calorific value, which is a measure of the energy content of the fuel, is measured in the calorimeter. This measured (upper) calorimetric value is not the technical (practical) calorific value, because the actual combustion in the hearth zone or in the engine cannot be carried out with the same recovery as is possible in the calorimeter. Consequently a so-called lower calorific value is used, i.e. the upper value adjusted for moisture and other losses. The heat of evaporation of the water in the fuel must be deducted from the upper calorific value in order to find the lower value.

When gas is burned in an engine, the practical question is not the calorific value of the gas but rather that of the gas-air mixture. The calorific value of the gas-air mixture is influenced by the mixing ratio between air and gas. The calorific value decreases both

when the ratio is increased and when it is decreased from the optimum. This is the case not only with wood gas but with other pegasus gases as well. By adjustment of the air valve the driver of the vehicle keeps the gas-air mixture so composed that the best engine performance results.

#### *Influence of Gasification Temperature*

As described in the previous section, the gasification reactions are strongly temperature dependent, and the reactions are most favorable at higher gasification temperatures. This should not be interpreted to mean that merely high temperature will produce high-energy gas. It is equally important that at a given temperature the fuel be amply responsive to carry the reactions to the equilibrium point. If the fuel fails in this regard, the calorific value of the gas will be unsatisfactory, regardless of the gasification temperature. On the other hand, highly responsive fuels can be gasified at low temperatures with good gas resulting. It appears also that the fuel's ash content is important, as it evidently has some reaction accelerating (catalytic) effect.

On the other hand, every temperature drop in the hearth zone, as from slag accumulation, is detrimental to gas quality, as it disturbs the attained equilibrium.

High temperatures come about as a result of total combustion of carbon to  $\text{CO}_2$ . The hearth zone temperature will go up as more air is passed through the hearth zone per time unit. As the air flow is controlled by the engine's r.p.m., high r.p.m. and hot gasification go together. The air speed must not be so great, however, that the oxygen cannot completely enter into the gasification, as otherwise incomplete reactions and excessive dilution from  $\text{N}_2$  and  $\text{CO}_2$  will result, as mentioned.

The  $\text{CO}_2/\text{CO}$  equilibrium shown in Fig. 3 is the typical result of a very long adjustment time, which is far from available in the vehicle pegasus. The reactions achieved in practice will therefore fall below the values in Fig. 3.

From the fact that complete combustion of the carbon determines the hearth temperatures, it can be deduced that the hearth temperatures rise, the more carbon the fuel contains. For example, the highest temperatures will be attained with anthracite, coke and charcoal. This rule of thumb is only valid for fuels of almost equal responsiveness. Fuels with high reaction response will begin

transformation of  $\text{CO}_2$  to CO already at low temperatures. Consequently, lower hearth temperatures are found in systems burning charcoal than in those burning coke, although both fuels show about the same carbon content.

### *Effect of Air Velocity*

The air velocity and the associated cross sectional area of the gasification zone are determined by the engine's gas consumption at full load, although dependent on the fuel's reaction response. Responsive fuels allow higher air velocity and a correspondingly smaller hearth cross section.

The composition of the pegasus gas can also to a minor extent be influenced by the distance which the smoke gas ( $\text{CO}_2$  and  $\text{N}_2$ ) must travel while the reduction reaction occurs. The longer it is, the more complete will be the conversion of  $\text{CO}_2$  to CO. In the vehicle pegasus the combustion zone will build to a thickness of about 5 cm, the adjoining reduction zone to some 20-50 cm. Insufficient thickness of the bed can therefore cause production of gas of low calorific value. In stationary installations it is desirable to adjust the height of the reduction zone in accordance with the air velocity, i.e. with the engine's gas consumption, but this is not feasible in automotive systems with their frequent and large variations in gas supply. Moreover, the vehicle pegasus functions with a fixed bed thickness which is adjusted to the fuel normally used. A criterion for the adequacy of the reduction distance, i.e. the reduction zone height, is provided by the gas temperature. Since the reduction process consumes heat, the gas temperature will be the lower as the proportional conversion of  $\text{CO}_2$  to CO increases.

### *Addition of Steam*

An effective way of favorably influencing the gasification processes lies in a properly adjusted addition of steam. Usually the steam is introduced into the air flow, altering the gasification in the direction of the water gas reaction.

Use of steam injection characterizes so-called "wet gasification" as distinct from "dry gasification." Which method to select will primarily depend upon the moisture content of the fuel. Wood, peat and lignite briquettes provide a great deal of moisture, and these fuels produce large amounts of condensates due to their chemical

structures, so that steam injection would be superfluous or even harmful, but wet gasification can be used advantageously with coke and anthracite. In actuality, when the former-fuels are used, even the dry gasification will be theoretically "wet" due to the fuel moisture and the condensates.

Steam injection is only desirable for gasification to the extent that a dissociation is possible with the production of  $H_2$  and  $O$ . Heat in the amount of 2570 kcal is needed per  $Nm^3$  steam. This is withdrawn from the hearth zone, which is cooled accordingly, so that, simultaneously, the equilibrium conditions are changed. When more steam is added than can be dissociated while maintaining the other gasification reactions, then the surplus will appear as steam in the generated gas, diluting it and clogging the filters. Besides, the weight of this moisture represents an unnecessary load on the vehicle.

The practice is, nevertheless, to drive with a small water surplus, because the cooling effect of the moisture is good for the walls of the hearth zone and causes fine grain in the slag.

It has further proven practical to adjust the steam injection to the gas flow in order to obtain optimum gas composition over a wide load range. This of course requires additional adjustment of the water level (compare Figs. JPI.2 and JPI.7). The steam is produced almost exclusively from the free heat in the gas or the radiation from the hearth. Steam injection thereby offers a welcome opportunity to utilize heat which would otherwise be lost, thus improving the system's heat budget.

The quantity of steam used is in practice also decided by nature of the fuel. There is for any given fuel a certain amount of water per kg fuel which will lead to the maximum calorific value achievable. If the optimum water quantity is altered upwards or downwards, the calorific value of the gas will drop, although not in the same manner with different fuels. For example, anthracite is quite sensitive to variations in water injection, whereas coke is only slightly affected, see Fig. 7. Fuels of high responsiveness to the gasification reactions will generally require less steam injection than fuels of low responsiveness in order to reach comparable calorific values.

In practice the steam injection with anthracite or coke amounts to 0.3-0.6 kg  $H_2O$ /kg fuel, whereas lignite coke only needs 0.25-0.35 kg  $H_2O$ /kg fuel, sometimes slightly more. If these quantities are used, some 60 to 80% of the added moisture will dissociate



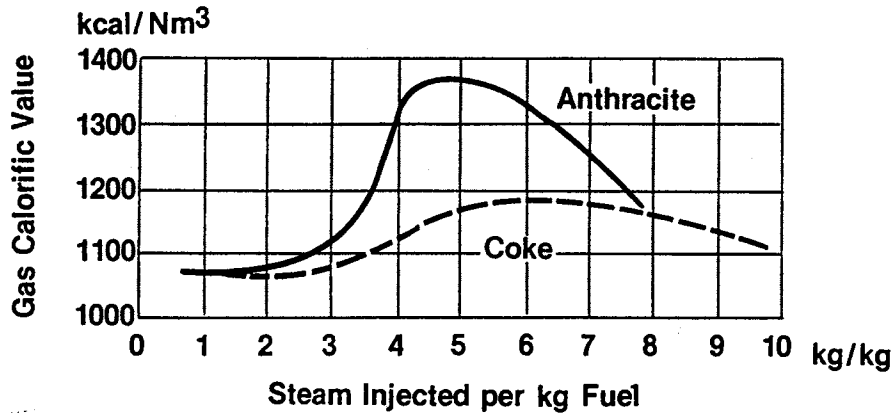

FIG. 7: EFFECT OF STEAM INJECTION ON THE CALORIFIC VALUE OF PEGASUS GAS FROM ANTHRACITE AND COKE

and enter the gas.

The advantages of wet gasification are then, higher calorific values, cooling of stack walls and hearth, and beneficial effect on the slag. Attending drawbacks are: a complicated design with greater trouble potential, added weight from water and tank, higher maintenance costs, danger of freezing in winter, and a higher moisture content in the gas.

Simplification has been attempted by utilizing a dry gasification into which engine exhaust is injected. The exhaust contains primarily carbon dioxide and nitrogen components in the gas. Hence some moisture is introduced, and the CO<sub>2</sub> and N<sub>2</sub> components are diluted. In the hearth zone, the CO<sub>2</sub> and H<sub>2</sub>O will dissociate so that the calorific value will increase with an attendant small fuel saving. This method furthermore offers substantial weight savings, as the injection apparatus and the water tank are omitted.

*Processes outside Gasification Zone*

Air flow, air velocity, zone thickness and moisture content have been mentioned as factors in controlling the gasification processes. Any further influence on the course of the gasification processes is generally not possible, particularly not after the gas has left the reduction zone. After that, certain other conversions take place between the constituents in the gas, which tend to reduce the calorific value. For example, a deterioration of the CO constituent will occur at high gas temperature with a resulting soot production:

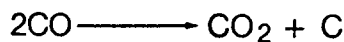

The loss in calorific value may be prevented by quickly cooling the gas. At about 600° the conversions between the constituents of the gas will cease. This has been called "freezing" the equilibrium. The composition of the gas will then remain unchanged until it reaches the engine.

Products from the degassing of the fuel also enter the gas during the period of heating to hearth temperature. These are hydrocarbons of high calorific value, such as:

Methane	CH <sub>4</sub> of 8550 kcal/Nm <sup>3</sup>
Ethane	C <sub>2</sub> H <sub>6</sub> of 15,370 kcal/Nm <sup>3</sup>
Ethylene	C <sub>2</sub> H <sub>4</sub> of 14,320 kcal/Nm <sup>3</sup>

They are found only in small quantities in the generated gas, usually totaling less than 5%, but they exert a relatively strong effect on the calorific value of the gas.

Some methane is created in the gasification processes, for example by:

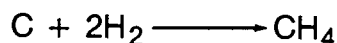

In this case the calorific gain is smaller, since the C and H<sub>2</sub> are taken from the gasification process. Still, 1% of methane thus formed will improve the calorific value by about 80 kcal.

#### *Inertia in Processes*

Changes in the gasification process conditions are primarily due to changes in the engine's gas demand and to increasing or decreasing the air velocity. If the pegasus supplies a vehicle engine, changes in gas demand will often occur on a short time scale and involve extremes of idling and full load. These strong variations in operating demand are met by the pegasus through an expansion or contraction of the hearth zone. Depending on the hearth shape, this will usually take place in the direction of the air flow. The system can only slowly accommodate these variations, since the reactions require time before they can build up to a level sufficient to meet the engine's gas demand. This systemic inertia is a characteristic which becomes most noticeable in vehicle installations.

If the engine is accelerated so that the gas demand rises, the air flow velocity will increase. But since the hearth zone's temperature and the surface of the fuel remain practically unchanged in the short time span of the acceleration, the increased air flow velocity will cause a shortening of the time available for reduction.

Less  $\text{CO}_2$  will be reduced to CO and the gas quality will be lower than it was during a period of even demand. A certain driver dexterity is necessary to overcome this "hole" in the gas flow. If the increased gas demand and the attendant higher air flow velocity persist, then the combustion in the hearth zone will be kindled, the reduction zone expanded, more  $\text{CO}_2$  formed and from this (at the now increased temperature) a larger share is converted to CO, until finally a new equilibrium is reached at the higher temperature level.

If the r.p.m. is reduced and with it also the air flow velocity, then the previous high-temperature gas production will linger for a while. The engine receives too much high-quality gas of which only part is used, while the rest passes out of the combustion chamber unused. Gradually, the temperature will drop from the reduced air flow, less  $\text{CO}_2$  will form, less  $\text{CO}_2$  will be reduced to CO, and the gas will become correspondingly poorer in calorific value. The system adjusts to this new equilibrium at a lower temperature.

By driving at high r.p.m. (using lower gears) it is possible to maintain a high gas quality in anticipation of peak loads, but only at the expense of economical operation.

The inertia of gasification is particularly noticeable in the long startup time required by pegasus vehicles, as well as when starting to drive and after short stoppages.

Gas production does not cease when the engine is turned off. It continues at a reduced level until the hearth zone has cooled down. The gas thus produced is vented into the air.

A system's inertia bears a certain relationship to the volume of fuel present in the hearth zone. Systems with hearth zones of small volume show generally less inertia, i.e. they are more responsive than systems of equal output but with larger gasification zones.

Due to the erratic gas demand and the attendant unavoidable losses, a vehicle pegasus functions less economically than one in a fixed installation, which usually will experience rather even loadings. But if the vehicle installation is subjected to even loading on a test stand, it will usually show higher performance than will fixed installations.

The varied demands placed on the vehicle pegasus in heavy traffic also make precise advance calculation of the gasification processes impossible and impose considerable experimental work on the designer. This is unavoidable because the influences of fuel responsiveness, surface condition, changes during gasification, etc., cannot be measured or accurately estimated.

## Chapter V

### THE HEAT BUDGET

The conversion of solid fuel to pegasus gas cannot take place without energy loss any more than can other energy transformation processes, but care should be exercised to keep losses at a minimum.

Gasification losses can be attributed to:

#### 1. Sensible heat of the gas

This stems from the fact that not all of the heat liberated in the oxidation is consumed in the subsequent reduction or dissociation. The conversions in the stack do not proceed completely to the equilibrium condition  $\text{CO}/\text{CO}_2$ , nor can the steam injection be so precisely adjusted that all the free heat can be consumed in steam dissociation. It is therefore necessary to accept a gas temperature of  $300\text{-}400^\circ$  at the stack exit and remove this sensible heat in the cooling and filtering stages, unless part of the heat can be transferred in preheating the air flow or in producing steam for the gasification process.

#### 2. Heat in the undissociated steam

The steam is a non-combustible ballast in the gas and must necessarily draw heat to reach the gas temperature. The effect of this loss becomes particularly noticeable when moist fuel is burned and most of the moisture fails to be dissociated in the gasification process.

#### 3. Conduction and radiation

The stack becomes hot in the hearth area and its heat is conducted to adjoining parts of the installation. Air flowing past the vehicle during driving will cool these hot pegasus parts and the heat will be lost thereby. This type of heat loss can be minimized by insulation of the hearth zone. The available heat is also frequently used for pre-heating the combustion air flow or for steam generation and is thus partly recovered.

#### 4. Heat contained in the removed slag and ashes

This item in the heat budget is naturally larger with fuels of high ash content. Included in this item should also be the unburned fuel which falls through the grate and is removed with ash and slag.

Because of the above mentioned losses, pegasus gas will never attain the calorific value which could be ideally expected from the chemical conversions. It will get closer, however, the more

carefully the gasification processes are protected from avoidable heat losses and the more successfully the free heat is recovered within the heat budget.

An example of the typical heat budget in a vehicle pegasus operated on a test stand and using wet gasification shows the following data:

<b>Incoming Heat</b>		
Heat in the solid fuel		%
Heat in combustion air flow		100.0
Heat in injected steam		0.3
Total incoming heat		<u>102.7</u>
<b>Usable Heat</b>		
Calorific value of the generated gas		82.0
<b>Heat Losses</b>		
Sensible heat in the gas		11.4
Heat in undissociated steam		3.4
Heat content of clean-out (ashes, slag and unburned fuel)		1.3
Radiation and conduction losses		<u>4.6</u>
Total outgoing heat		102.7

This calculation uses the fuel as basis of the 100% figure. The same relationship can be displayed in a flow diagram, as shown in Fig. 8.

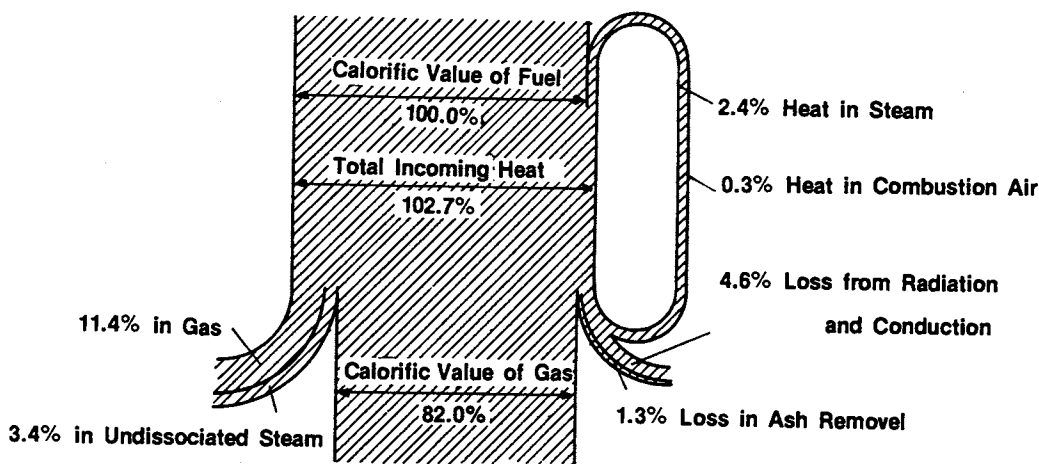

FIG. 8: HEAT BUDGET IN FLOW DIAGRAM OF PEGASUS UNIT USING WET GASIFICATION AT FULL, CONSTANT LOADING

The ratio of fuel calorific value to gas calorific value, usually expressed as a percentage, gives the efficiency of the system. It is computed thus:

$$\text{Efficiency in \%} = \frac{\text{gas calorific value}}{\text{fuel calorific value}} \times 100$$

Example: From 1 kg generator fuel (anthracite) with a calorific value of 7800 kcal/kg is generated 4.4 Nm<sup>3</sup> gas with a calorific value of 1200 kcal/Nm<sup>3</sup>. The efficiency is then:

$$E = \frac{4.4 \times 1200}{7800} \times 100 = 67.7\%$$

Efficiencies attained by vehicle installations reach about 80% in experiments on a test stand. These results drop to between 60% and 70% in actual operation, and high heat losses may even depress the figure to about 50% in some cases.

## Chapter VI

# THE FUELS

### *AVAILABLE CHOICES*

A pegasus unit can be designed to gasify virtually any solid fuel. This includes the fossil fuels from anthracite through all of the bituminous coals to lignite and peat, as well as the various cokes that can be derived from these. Further included are all of the wood species, which must be classified as replaceable and therefore can be considered inexhaustible, if properly managed. Wood derivatives such as paper are also usable with some preparatory processing, and so are undoubtedly the "fuel pellets" which are currently being produced experimentally from garbage.

Fuel quality is basically a function of carbon content, and it is useful therefore to see how the various types compare by this criterion. Fig. 1 shows the composition of some solid fuels, and it will be noticed that the carbon content of natural fuels is lowest in wood and increases through lignite to anthracite, which has the highest carbon content. Approximately parallel with the carbon content runs the line showing lower calorific value of the natural fuels. Pre-processed fuels such as charcoal and coke have greater carbon content than their parent materials.

It is natural for solid fuels to show greater variation in chemical composition than liquid fuels, with consequent greater variations in pegasus gas. In the hearth zone the fuel will all show carbon contents of 80% to 90%, as hydrogen and oxygen have been removed in the previous drying and distillation process. Even those fuels with naturally lower carbon content will therefore show an increase in carbon content in the hearth zone.

Besides carbon, hydrogen and oxygen, there will also be a small quantity of nitrogen, as well as some sulphur and non-combustible ash content. The sulphur will in the gasification process be partly converted into sulphuric gases and become part of the gas flow. Partly, it will combine with the inert constituents and deposit in the slag. The fuel's ash content will remain as inert leftovers from the gasification process and will partly melt and sinter into slag.

If a choice of fuels is possible, selection would be based at least in some degree upon consideration of calorific value, although there are other pertinent factors, which will be discussed later. In Table 6 are listed the average calorific values of a number of solid fuels. With the exception of paper, these have all been used for gasification purposes, and paper is excepted only because it was scarce in war time Europe. In the U.S. today, it is undoubtedly the

**TABLE 2—Calorific Value and Chemical Analysis of Some U.S. Wood Species**

Wood Species	Calorific Value kcal/kg (kiln-dried)	Constituents in % by weight (dry)			
		C	H	O	Ash
Pitch Pine	5790	59.0	7.2	32.7	1.1
Cypress	5040	55.0	6.5	38.1	0.4
Yellow Pine	4910	52.6	7.0	40.1	0.3
Maple	4670	51.6	6.6	41.3	0.5
Fir	4600	52.3	6.4	41.2	0.1
Poplar	4560	51.6	6.3	41.4	0.7
White Ash	4560	49.7	6.9	43.1	0.3
Elm	4500	50.4	6.6	42.3	0.7
Beech	4490	51.6	6.3	41.5	0.6
Hemlock	4440	52.4	5.9	41.2	0.5
Red Oak	4440	49.5	6.6	43.7	0.2
Shellbark Hickory	4430	49.7	6.5	43.1	0.7
White Birch	4420	49.8	6.5	43.4	0.3
White Cedar	4230	48.8	6.4	44.4	0.4
Black Oak	4180	48.8	6.1	45.0	0.1

most universally available solid fuel.

The fuel, combustion air and steam react in the gasification process at a speed which depends on the temperature and air flow velocity. It also depends on the type of fuel as well as on grain size and moisture content. The composite effect of these factors will thus profoundly affect the results of the gasification and the usability of the gas.

We shall now briefly discuss some common fuels and then



go into the various characteristics which determine the quality and suitability of a solid fuel.

### WOOD

Since wood was used extensively as pegasus fuel in Europe during World War II, and since it is plentiful in many parts of the U.S., it merits particular attention. Wood consists of carbon, oxygen, hydrogen and a small amount of nitrogen, some 0.5%-1.5%. Viewed as a pegasus fuel wood has several advantages. The ash content is quite low, only 0.5%-2.0% depending on species and presence of bark. Wood is free of sulphur, which is a dangerous contaminant that easily forms sulphuric acid, causing corrosion damage to both engine and pegasus. And wood is easily ignited, a definite virtue for pegasus purposes.

The main disadvantages are bulkiness and moisture content. As it is relatively light, one cubic meter will accommodate only 250-300 kg pegasus wood. Moisture content is notoriously high in wood fuels and must be brought below 25% before use in a pegasus. By weight, the moisture in green wood runs from 25% to 60%, in air dried wood from 12% to 15%, and in kiln-dried about 8%. It can be measured quite easily by carefully weighing a specimen of the wood, then placing it in an oven at 105° until the moisture is purged completely. By weighing again after the drying, the moisture content can be determined as the weight loss in the drying process.

Hardwood is decidedly preferable, but softwood is usable. The favored species in Europe was beech, but several other species are as good, some even slightly better. Table 2 gives a comparative overview of some common American species. The listed calorific values are averages and will vary within a species as a function of density. The densities, and with them the calorific values, vary a good deal within species depending on growth conditions, with a slow growing tree attaining higher density than a fast grower.

Table 3 summarizes the attributes bearing upon the suitability of wood for Pegasus gasification.

### CHARCOAL

Real charcoal is not easy to come by. In the old days it was made in charcoal piles by hand stoking, but today it is an industrial product. Most of the so-called charcoal briquettes sold for barbecue use are not pure charcoal but compressed from sundry coal offal.

Charcoal is excellent fuel of high calorific value, see Tables 5 to 7, and virtually free of tar and sulphur. Ignition point is about 300°. The best charcoal is derived from hardwood, as it is less susceptible to powdering and fragmentation than softwood charcoal.

**TABLE 3—Suitability of Wood for Pegasus Gasification**

	Preferred	Usable	Not Suited
Wood Type	Hardwood as per Table 3	Any wood type; dead wood	Unpeeled wood with high bark content
Form	Shop offal, mill ends	Cordwood, kindling, construction offal	Sticks, branches under 2 cm dia.
Moisture	15%	Air dried, kiln dried 10%-25%	Freshly cut, "green" wood
Preparation	Low admixture of impregnated or painted wood	Painted and treated wood, railroad ties, power poles, etc.	Pressure treated wood, dirty boards with nails, wires, etc.

## COAL

When discussing coal it is necessary to be quite specific about the kind or type. Actually a more or less continuous series exists from wood to coal, see Table 4, and any and all of the solid fuels therein may be used in the pegasus.

Bituminous coal is the most abundant fuel in the United States, and gas production for cooking and heating from both lignite, soft coal and hard coal is a well developed technology. Consideration of these fuels for pegasus gas has never aroused any interest, however, as oil has been plentiful and seemed inexhaustible. For the vehicle pegasus, anthracite is the most desirable of the coals, as it has low sulphur content and very high carbon content. Its high density makes it possible to carry three times as much anthracite as wood in the same space. One cubic meter accommodates about 800 kg anthracite. The ash content is about 4%.

**TABLE 4—Composition of the Series Wood-to-Coal, Moisture and Ash free**

	C	H	O	N	S	kcal/kg
Wood (avg.)	49.3	6.1	44.1	0.5		
Peat (avg.)	60.4	6.6	32.1	0.9	trace	
Lignite, brown	72.0	4.9	21.1	1.2	0.8	6890
Lignite, black	78.0	5.4	18.9	1.2	0.5	7330
Bituminous Coal (avg.)	84.0	5.4	7.4	1.6	1.6	8460
Semibituminous	90.2	4.5	3.5	1.2	0.6	8860
Anthracite	92.2	3.2	2.7	1.0	0.9	8470

*From Jerome J. Morgan, "Manufactured Gas"*

## Chapter VII

# FUEL CHARACTERISTICS

### *GRAIN SIZE*

The first consideration of the condition of the fuel is its coarseness or grain size. Since such labels as "coarse" or "fine" grain are too vague, the criterion most commonly used is the mean size range. Grain size 10 to 18 mm thus indicates that the smallest particles measure about 10 mm, the largest about 18 mm. The fuel will then pass an 18 mm screen, but only a very minor part will pass a 10 mm screen. Fuel particles which in this case measure over 18 mm are classified as oversize, whereas those which measure less are labeled undersize.

The following coarseness or particle sizes have proven useful in practical generator work:

WOOD: pieces ca. 8 cm long and 5 cm diameter

PEAT: pieces with edges 2.5 cm-8 cm

LIGNITE BRIQUETTES: primarily industrial briquettes of 6 cm dia. and 4 cm thickness and a weight of about 150 g each, occasionally a smaller type of 60 g weight.

ANTHRACITE: 6 to 18 mm.

Uniformity of size is a requirement of quality pegasus fuel, so that no more than 10% of the fuel, by weight, is classifiable above and below the nominal size range.

Oversize pieces will make gasification generally difficult, because the ratio of surface to volume is smaller than in the lesser grain sizes, and a large surface area is essential in starting the gasification process. Moreover, the larger interstitial spaces permit the air ready passage without reacting in the gasification.

Undersize particles cause excessive dust problems and block the air flow through the fuel pile. A large proportion of undersize fuel can cause the dust fraction to be carried with the gas and build gas ducts through the pile through which the air will flow, taking little or no part in the reactions. When the unused air then mixes with gas in the hearth zone, an undesirable local reaction will occur, causing local gas combustion, hot spots in the stack wall, heat losses and increased slag formation.

Undersize grains also tend during driving to separate in the pile and in the hearth zone, migrating toward the center and leaving the coarser material along the wall. This causes the gas to flow

chiefly along the wall, where the coarse grain offers less resistance, and shortened reduction time and poorer gas quality ensue.

In wartime Europe, slow and cumbersome transit often caused the fuel to deteriorate by breakdown or powdering between supplier and user. In many cases it was necessary to screen off the smaller grain before loading the stack.

In the case of wood, oversize pieces occur as bulky chunks which create bridges in the pile and obstruct the gradual feed of wood to the hearth zone. Such bridge building leads to the so-called "wood-burner" with poor gas production. Bridge building also slows down starting and restarting.

Wood that is too thin such as branches, sticks and so forth, is undesirable in the stack, as it will form a fragile charcoal from which dust will result, together with blockage of the hearth zone.

For the above reasons, good pegasus fuel must contain only the optimum grain sizes. These requirements are less severe for stationary and marine installations, as the adjustable bed height will largely even out differences in grain sizes. This is not possible in the vehicle pegasus with its fixed and rather shallow bed thickness.

### *BULK WEIGHT*

The weight per volume unit of the loosely piled fuel is termed its bulk weight. It is determined by the fuel's density and grain size, plus to a lesser extent by the grain shape and porosity.

Fuels with high bulk weight are particularly advantageous if they show good calorific value, as then the travel range on one stack filling is extended. Lower bulk weight requires more space for transporting and storing, hence is less desirable.

**Table 5: Average Bulk Weights**

Charcoal	200 kg/m <sup>3</sup>
Peat	320 kg/m <sup>3</sup>
Wood	350 kg/m <sup>3</sup>
Lignite briquettes	760 kg/m <sup>3</sup>
Anthracite	800 kg/m <sup>3</sup>

A comparative basis for the travel range of generator fuels is provided by the energy content per  $m^3$  of the stored fuel. This can be computed as the product of bulk weight and calorific content. Average values are given in Table 6.

**Table 6—Calorific Values of Pegasus Fuels**

Fuel	Lower Calorific Value	kcal x $10^6$ per $m^3$ in bulk state
Cellulose (Paper)	3500	—
Wood	3700	1.3
Charcoal	7000	1.4
Peat	3400	1.1
Brown Coal Briquettes	4800	3.6
Brown Coal Coke	5800	3.5
Hard Coal Coke	6800	3.4
Anthracite	7800	6.0

### *DUST*

All generator fuels carry and produce dust. Dust which is carried into the gasification process and further into the pegasus installation must for several reasons be eliminated. It will increase resistance to gas passage in the stack and leads to deteriorating gas quality and erratic production, as it blocks the even air flow in the hearth zone.

When contained in the gas, dust from the fuel, as well as from coke and ashes produced in the gasification process, places an undesired strain on the filters. Special dust catchers must keep the gas almost dust free to avoid wear on the engine parts.

Dust will adhere to the fuel or may reside in its porosities. There will also be some powdered material ranging in size from fine dust to small particles, depending on the type of fuel. The resistance of a fuel to breaking down into crushed or powdered form should be as high as possible to minimize the detriments from dust content.

### TAR CONTENT

How large a tar quantity a given fuel will produce by passage through the hearth zone will primarily be determined by the gasification process which is applied to that fuel. An example of a wood of high tar content is beechwood, which can yield up to 80 g tar per kg when heated to 400°. In contrast, coke from hard coal will usually show less than 1 g of tar residue.

Tar is one of the most unpleasant constituents of the gas, as it will deposit in the carburetor and on the intake valves, causing sticking and troublesome operation. It is consequently desirable so far as possible to burn the tar in the hearth zone or transform it into gaseous or low-boiling point components, or alternatively to remove it from the gas in the tar separator.

The tar has a relatively high calorific value of about 8500 kcal/kg which is partly lost to the gas, when the tar is burned in downdraft gasification. But part of the tar will dissociate and form gaseous hydrocarbons of high calorific value, improving the pegasus gas. However, the dissociation consumes heat, which is drawn from the hearth zone.

The fuel's content of volatile components gives an indication of the tar content. These are the parts which will readily evaporate when the fuel is heated.

Nevertheless, it is not possible either from laboratory work or from measuring the volatiles to establish the tar content accurately, because the effect of the gasification is different from the effects produced in the test procedures.

### MOISTURE CONTENT

All pegasus fuels contain moisture, either due to their natural state, as with wood or peat, or from manufacturing processing as in lignite briquettes, or because the fuel has absorbed atmospheric moisture during storage, as often happens with several types of coke. In consequence, the moisture content varies greatly among the fuels, as can be seen in Table 7.

Moisture in the fuel stems from the so-called free moisture, which will be given up to the atmosphere in the course of drying, and the so-called hygroscopic moisture which will be expelled by heating to 105°. Together they constitute the fuel's total moisture content.

**Table 7: Average Moisture Content**

Fuel	Moisture Content in % by Weight
Wood, ready for pegasus	15-25
Wood, green	up to 60
Charcoal	3-5
Peat	20-25
Lignite briquettes	13-16
Anthracite	5

The moisture is purged from the fuel in the drying zone and in downdraft gasification goes to the hearth zone so that it dissociates, giving the gas a higher hydrogen content. But if the moisture content is so high that undissociated water remains, which must be evaporated, then to enter the gas as steam, it will place a heavy strain on the cooling and filtering units, causing lower gas quality and condensation in undesirable places. The aim must therefore be to use fuel with the lowest possible moisture content, ideally fuels which in conversion into coke give off considerable water condensate drawn from the parent fuel.

Fuels for updraft gasification (coke and anthracite) are of lower moisture content. This is advantageous as the moisture which is purged in the drying zone largely must enter the gas directly and there will cause the drawbacks mentioned above. Hence even these fuels should be used in their driest state. Fuels with a pronounced reaction responsiveness should have a moisture level of 10%-15% to prevent spontaneous ignition during transport and storage.

High moisture content cools the hearth zone strongly. Not only will gas calorific value hereby suffer in downdraft gasification but tar dissociation will also be impeded so that the tar content of the gas increases.

Steam will condense as water on the fuel during stopovers or when shutting down the system. This impedes restarting of the gasification, as the water must first be evaporated from the fuel. It is therefore recommended to allow steam to escape through the fuel filler opening during stopovers, when high-moisture fuels are used, if this is possible in the local circumstances. Some stack designs even provide condensation baffles, see Fig. 35, upon which the steam will condense and which will channel the water to the outside.



## ASH AND SLAG

The inert constituents, or ash content, of a pegasus fuel will in many cases determine whether the fuel can be utilized economically. It is here not just a matter of ash content but also a question of the behavior of the slag in the circumstances prevailing when the installation functions.

Ash content of pegasus fuels will vary. From a low of 0.6%-1.0% by weight in wood, see Table 3, the proportion of inert constituents reaches about 20% for lignite coke used in pegasus units, and yet higher when this fuel is used for other purposes.

It is obvious that a high ash content is undesirable for the reason alone that it represents unnecessary ballast all the way from manufacturer to user and ultimately through the gasification. Even when the ash is harmless, it still requires removal and hence causes a maintenance expense, which rises with higher ash content.

The quantity of unburned material that must be removed after the gasification process is not always equal to the ash content. On one hand, ashes may volatilize in the hearth zone, while on the other hand carbonized fuel often must be removed with the ashes and slag. In some lignite fueled systems the gasification has been so arranged that carbonized fuel is led out of the hearth zone to act as a tar filter, through which the gas must pass.

The ash portion of the fuel is also detrimental to the gasification insofar as it shelters the points in the fuel where ignition is initiated and thus lowers the fuel's reaction response. It is also known, though, that a certain ash content is necessary for this same reaction response. If that is removed, for example through chemical de-ashing processing, then the reaction response will suffer accordingly.

Smooth and uniform ash formation and ash drop are desirable for uninterrupted functioning of the system. The ash particles should individually be liberated and drop through the grate in the course of the gradual gasification of the fuel, thus clearing the way for the reactions to proceed on the surface of the fuel pieces. In contrast to such cooperative ashes there are also fuels which instead of easy ash separation will form an ash crust, preventing air access to the fuel surface. As a result, the gasification process will migrate from the hearth zone to other locations in the stack.

The difficulties deriving from the fuel's ash content can be reduced by placing a smaller load on the hearth zone, but this means

an increase in volume and weight of the installation.

In the past, experimentation was carried out to reduce the ash content by treatment with, for example, dilute hydrochloric acid. Although good results were achieved in tests, proving out the feasibility of such procedure, the high cost and heavy demand for acid would nevertheless discourage such treatment on a large scale. Anyway, as already mentioned there are undesirable side effects to very low ash content, such as the negative influence on the fuel's reaction response.

The best way to minimize difficulties arising from the ash content seems to be in discriminating selection of low ash content fuels or beneficiated coals, and further by design of effective automatic cleaning equipment in the pegasus.

Trouble in the functioning of the pegasus seems to be proportional to the sintering or smelting of the ashes at the gasification temperatures, i.e. slag formation. The slag displays altogether different characteristics from those of the parent ashes. How large a part of the ashes will be melted down as slag depends not only on the gasification temperature but on the melting point of the ash as well.

**Table 8: Melting Points of Ashes in °C**

Lignite	1200-1500
Coke	1200-1400
Anthracite	1200-1400

Since the pegasus hearth temperature almost always exceeds 1200°, usually between one and two thirds of the ashes from fossil fuels will sinter. In the crossdraft system the temperature will be between 1800° and 2000° in the hearth zone, so that all ashes will form into slag.

For continued gasification it is necessary to remove the slag from the stack. The slag in the hearth zone will disturb the uniform distribution of the air flow, and a displacement of the gasification zone will ensue in unfavorable circumstances. In hearths lined with firebrick, a fusion may occur between the slag and the lining. Removal is time consuming and expensive and sometimes damages the lining. It is not unusual for the slag to encapsulate unburned fuel, which is then removed with the slag, lowering the economy of the system. The vehicle's travel distance between slag removals is also

affected by the degree of slag deposition.

The struggle against slag should begin at the time of choosing the fuel. For crossdraft systems in which the entire ash is converted into slag, only low ash content fuels should be employed. Updraft systems do not have this limitation, as only part of the ash is melted in the lower hearth zone temperatures, and the water injection which is common in this type of installation will favorably affect the slag formation by building smaller lumps.

It has also been tried to make the slag more fluid and tractable by admixture of various fluxes which may also cause easy fragmentation into small readily removable pieces after solidification.

The fluxes are chosen to interact chemically with the slag components, which may vary greatly. Slags from lignite fuels comprise a basic reacting mass rich in calcium oxide (CaO) and magnesium oxide (MgO), whereas hard coal fuels produce sour slag rich in clay ( $Al_2O_3$ ), ferric oxide ( $Fe_2O_3$ ) and silicic acid ( $SiO_2$ ).

### *REACTION RESPONSE*

If the character of a fuel is such as to accelerate the chemical conversions so that they will closely approach the chemical equilibrium despite the short time available in the vehicle pegasus, then the fuel is said to have a high reaction response. Such fuel for various reasons facilitates the functioning of the pegasus. Moreover, an extensive conversion of the  $CO_2$  to CO results from the reactions with a concomitant improvement of the calorific value of the gas. This advantage can also conversely be exploited to depress the prior  $CO_2$  production in the hearth zone by reduced air flow, thereby bringing less diluting nitrogen into the pegasus gas, simultaneously also reducing the stack's heat losses and protecting the hearth materials from overheating.

Reaction response is an idea that is sensed rather than actually understood at this stage. It depends on the nature of the fuel but also varies with the changes that take place during combustion. Since a reaction responsive fuel accelerates the conversion speed, commencement of the gasification will take less time, i.e. the start up time will be shortened. The same pertains to restarting the gasification after temporary shutdown. Such fuel can, above all, follow the fluctuations in the gas demand more swiftly as they continually occur during driving. In other words, such fuel renders the pegasus more flexible.

The reaction response appears to be primarily determined by the fuel type. It is a general rule that the geologically young fuels such as wood, peat and lignite are superior to the geologically older fuels of the hard coal group in regard to reaction response. It can also be deduced from this that the reaction response is better in high-tar fuels than in low-tar ones. This rule is not without exception, as some tar free lignite cokes possess outstanding response qualities. But a certain connection exists with the content of volatiles, insofar as high volatile content leads to quick start-up. Production of pegasus fuels from coal should therefore be aimed toward providing a measure of volatiles in those fuels. The content of volatiles found to exist, on the average, in fossil pegasus fuels is shown in Table 9.

**Table 9: Average Content of Volatiles**

Lignite briquettes .....	44%
Lignite coal .....	7%
Hard coal coke .....	5%
Anthracite .....	7%

The condition and grain size of the fuel play a further important role in the reaction response. As the conversions between glowing carbon and the air flow, and perhaps with injected steam, take place at the common interface, i.e. the surface of the fuel grains, this surface is naturally important to the success of the fuel reactions. A rough, fissured surface is apparently advantageous. It should also be realized that only the side of the fuel grain exposed to the air flow will be involved in the gasification, whereas the sheltered side will be disadvantaged in this regard. To be sure, this will be evened out by the continual displacement of the fuel grains, but the total effect is that only part of the hearth fuel will be exposed to the air stream at any given time. It is thus desirable that the fuel grain has a large surface area relative to its volume. It follows that the grain size will influence the fuel's reaction response. The smaller the grain, the more surface is available per unit of weight. But dust formation and the higher air flow velocity as well as the likelihood of more slag deposit make it impractical to go below a certain grain size.

A low ash content will also help toward gaining a large reaction surface, for the ashes will partly cover the surface, particularly when the fuel has a low tendency to shed or drop the ashes.

Porous fuels are reaction responsive, for beside their

exterior surfaces pore surfaces will provide ignition points for the gasification. For example, at almost the same chemical composition charcoal, which is highly porous, will be much more responsive than anthracite with its dense, firm structure and smooth surface.

A fuel's reaction response can become substantially less favorable in the course of the gasification process. This is particularly evident in fuels containing volatiles, as the response deteriorates after the volatiles disappear. A similar effect manifests itself in porous fuels, as the pores will clog with ash and coke particles in the gasification process.

The multiplicity of factors precludes a precise forecast of a fuel's reaction responsiveness, but many suggestions have been made of ways to measure it. Most proposals have involved blowing air or carbon dioxide over a layer of glowing fuel and measuring the conversions. So far, good agreement has not been obtained between test results and the actual performance of the fuel in the pegasus.

It has alternatively been suggested to use as a performance criterion the ignition temperature, i.e. the temperature at which the fuel will commence burning in air or in oxygen. Low ignition point would be equated with high response. Aside from the fact that substantial differences in ignition point values appear when different measuring techniques are used, it is indefensible to draw conclusions about the responsiveness because the fuel characteristics are profoundly altered by passage through the drying and distillation zone before entering the hearth zone.

A definite judgment about responsiveness is as with many other fuel characteristics only possible after practical applications in the pegasus.

### *STABILITY OF COMBUSTION*

In order to maintain a qualitatively and quantitatively uniform gas flow it is a prerequisite that the fuel grains undergo no other changes than that wrought by the progress of the gasification. This means that a certain stability of combustion is required. Fuel grains that disintegrate or burst in the hearth will unfavorably change the prevailing gasification conditions. The fragments increase the resistance to air passage, impeding engine performance. An increase in ash particles in the gas will also be noticeable with an attendant strain on the filters. Higher loss will be sustained of unburned fuel removed with the ashes, and a higher fraction of the ashes will form

into slag.

Vehicle operation with strongly varying gas demand will make stability of fuel consumption a prime requirement.

Most of the fossil fuels have sufficient combustion stability. When grain breakdown does occur, as in charcoal produced in the gasification of wood fuel, it will not be bothersome if only large fragments are formed, as these will participate in the gasification process. This is the case, for example, with beechwood derived charcoal. Pinewood charcoal will on the other hand swell and form more dust than beechwood charcoal.

Summarizing the requirements that a fuel must meet so that satisfactory production of gas can ensue, the picture looks like the arrangement in Table 10.

**Table 10: Summary of Required Qualities in Pegasus Fuels**

Requirement	Reason
Proper grain size within narrow limits	Large grains will gasify poorly, small grain lowers performance due to passage resistance
Low content of dust and small fuel particles	Small particles and dust lower the gas extraction and increase dust in the installation.
Resistance to breakdown	
Low ash content and benevolent ashes	Ash content and behavior determine maintenance cost, incidence of repairs and economy of the installation
Low moisture content	Undissociated water strains the cooling apparatus and impairs the heat budget
Low tar content	Insures with downdraft gasification complete tar dissociation and tar free gas
Low sulphur content	Lowers corrosion in gas piping and obnoxious odors
High reaction response	Essential in forming gas of high calorific value, quick start-up and flexible response at varying gas demand
High calorific value and high bulk weight	Permits large driving distance per filling, lowers volume to be transported and stored

## THE PEGASUS UNIT

The difficulties in operating gasification systems go up rapidly when the listed requirements remain unmet. Simultaneously, higher operating, maintenance and repair costs are encountered.

# Chapter VIII

## PEGASUS TYPES

### *THE METHODS OF GASIFICATION*

In the basic model of the vehicle pegasus a stack encloses a fuel column through which the air stream passes. The fuel will by gravity gradually descend into the hearth zone. This basic design is derived from the old stationary model of industrial gas generator. It may perhaps change in the future, for example by separation of the fuel pile from the gasification zone and controlled feeding of the fuel into gasification, as this offers certain advantages.

The air stream can be led in the same or in the opposite direction of the fuel feed, or it may even be aimed crosswise to the feed. In consequence, different methods of gasification are possible. The three most important designs provide:

Updraft gasification  
Downdraft gasification  
Crossdraft gasification

Each method allows the fuel gradual entry to the hearth zone. It is thereby slowly heated and eventually reaches the temperature of the hearth zone. Volatiles in the fuel are gasified before reaching the hearth zone, so that only charcoal or coke are gasified here.

The course of the gasification processes is fundamentally the same in all three designs, and the processes are equally applicable to any of the fuels, but the smoothest and most trouble free operation is achieved by proper combination of method and fuel type.

Choice of pegasus design is therefore governed by the type of fuel, whether it must accommodate high-tar or tar free (fossil) fuels. Tar containing fuels such as wood, lignite and peat should be gasified in downdraft systems, whereas slag building fuels with low or no tar content should have updraft.

### *UPDRAFT GASIFICATION*

The operating principle of updraft gasification is shown schematically in Fig. 9. In this system the fuel column rests on a grate through which the stream of air and steam enters. Above the grate the hearth zone develops, and the reduction zone lies above that. The gas is drawn off above the fuel column, after first having committed part of its heat to drying and distillation in the upper part of the column.



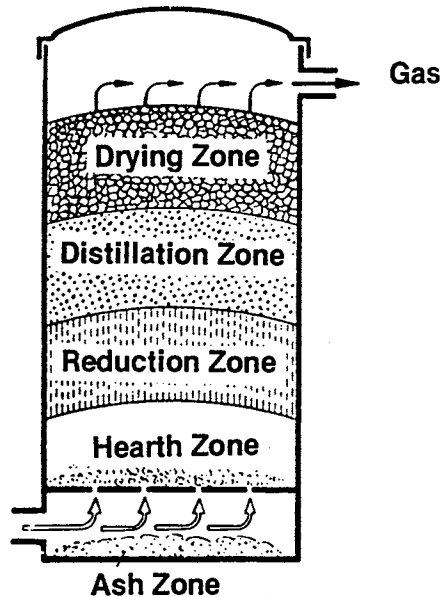

**FIG. 9: DIAGRAM OF UPDRAFT GASIFICATION**

Most stationary industrial systems were designed to work in this fashion. The oldest design is the cylinder gasifier with natural draft which was originally used for heating gas production. In this the natural draft draws the air stream through the hearth's fuel bed. Other designs retain the cylindrical interior but show modifications in the hearth zone. Fig. 10 shows a type with stacked grate, where the air is distributed into the hearth zone through stair-shaped slits. Fig 11 shows a so-called turn grate model, a common industrial type in days past with a grate that rotates together with an attached water trough, breaking up the slag through an eccentric arrangement. Systems of this design were used industrially for large scale gas production. The principles in Figs. 9 and 10 have also been used for vehicle installation, and the system shown in Fig. 11 has been automotively used in ships.

Updraft gasification is characterized by the extended hearth zone, which allows numerous ignition points where the gasification processes can commence. This gasification system is therefore not sensitive to the choice of fuel and is particularly suitable to gasification of fuels with low reaction response. It is almost invariably employed with steam injection. Air and steam are pre-heated by the coal and ash bed on the grate, and the grate itself is

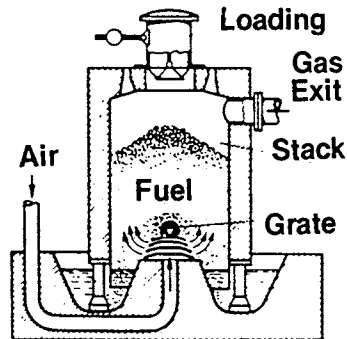

FIG. 10: PEGASUS WITH FIXED, STACKED GRATE

cooled thereby and the slag formation improved. The large volume of the gasification zone offers a certain delay in response to fluctuations in gas demand, however. It also requires longer time for pre-heating and higher fuel consumption in the start-up. Only tar free fuels such as charcoal or anthracite are suitable for this type of air flow. If the fuel contains tar, as do wood, peat and lignite, the tar is gasified and drawn off in the gas stream. A tar separator is then needed in the system to prevent the tars from entering the engine.

Sulphur gases are not drawn through the hearth zone but pass into the gas. If the gas is drawn off above the fuel column, as shown in Fig. 9, it will heat the entire fuel filling and remove the tar. As a result, the entire filling will shortly be carbonized and its reaction response lowered. In order to avoid this, the gas may be led

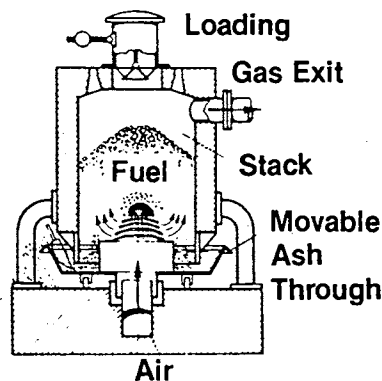
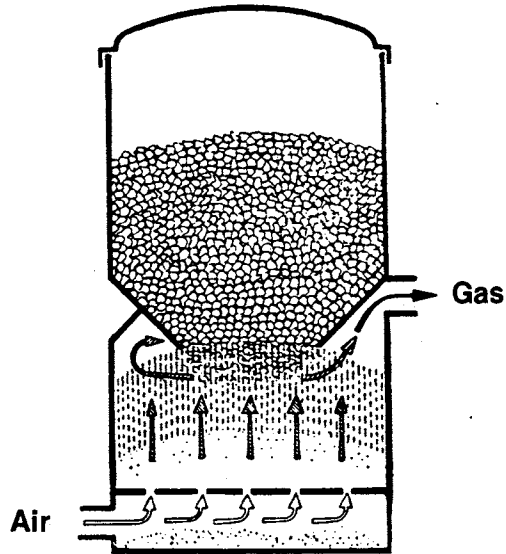

FIG. 11: PEGASUS WITH MOVABLE GRATE AND AUTOMATIC ASH REMOVAL

through only part of the fuel column and removed from the circumference, see Fig. 12.



**FIG. 12: UPDRAFT GASIFICATION WITH GAS EXIT BELOW FUEL STORAGE**

A modified updraft type is found in the diagonal-updraft gasification in Fig. 13, whereby the air is fed through a nozzle into the lower hearth zone and the gas drawn off oppositely at a higher level.

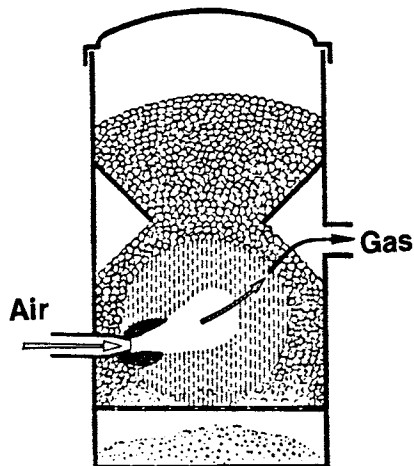

**FIG. 13: DIAGONAL UPDRAFT GASIFICATION**

**DOWNDRAFT GASIFICATION**

The principle of downdraft gasification is shown schematically in Fig. 14.

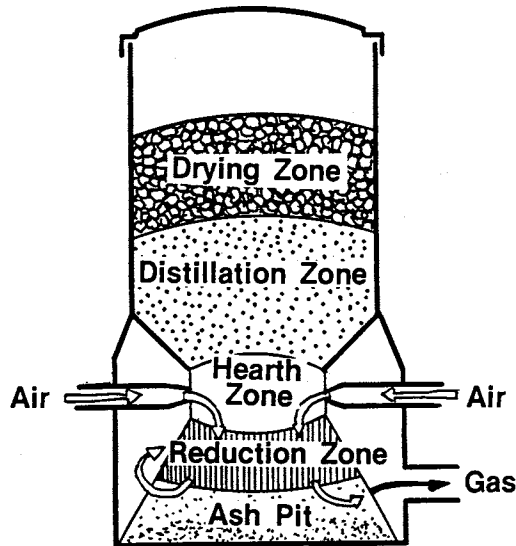

**FIG. 14: DIAGRAM OF DOWNDRAFT GASIFICATION**

The air enters circumferentially and draws all of the gaseous-fuel components down into the hearth zone, there to enter into the gasification processes. It is therefore in this system not possible for the steam, condensates, tar and other volatiles directly to enter the gas, as in updraft gasification. Sulphur, tar and some moisture will instead be exposed at high temperature to the carbon in the hearth zone, there to undergo partly combustion and partly dissociation, so that the gas can proceed tar free to the engine.

To facilitate the above described purposes, downdraft gasification systems have developed a characteristic funnel shaped constriction of the hearth at or just below the entry of the air stream. This constriction or throat causes a localized increase in the air flow velocity with a concomitant localized temperature rise, which is essential for a complete conversion of the tars into gaseous components. On the other hand, the high temperature adversely affects the walls of the hearth zone, and the narrowed cross section increases the resistance to air passage.

This type of gasification gives gas of low tar content, even when high tar fuels are used, and is therefore almost exclusively

employed in gasification of wood, peat and lignite briquettes. But it is also suitable for low tar fuels when these simultaneously are low in ash content.

The downdraft is unsuitable for fuels with high ash content, because the high temperatures created in the narrow throat section will sinter the ashes into slag, which is difficult to remove and causes functional trouble. It is also less suitable for fuels with low reaction responsiveness, as these demand particularly high temperatures, which on a continuous basis will cause deterioration of the hearth structure.

Compared with the updraft system, downdraft gasification uses a substantially smaller space for the reactions and consequently is able more swiftly to accommodate fluctuations in gas demand. The startup time is also thereby minimized. But the smaller reaction space requires uniform fuel feed. If irregularities occur in this respect, such as bridge building in the fuel column of the stack, it will be immediately noticeable, as the already modest sized reactive surface will be further diminished.

The air entry can in the downdraft system take place either through nozzles arranged at the circumference of the hearth zone, see Fig. 14, or through a center nozzle, see Fig. 15. The air can in the

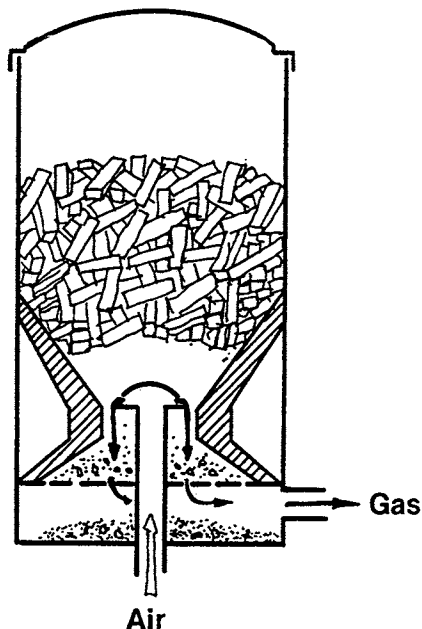
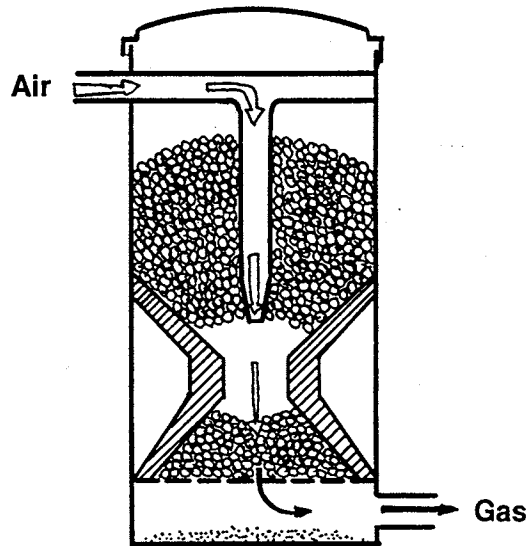

FIG. 15: DOWNDRAFT GASIFICATION WITH CENTER NOZZLE AND AIR ENTRY FROM BELOW

latter case be provided either from below, see Fig. 15, or from above, see Fig. 16. In the past, the circumferential arrangement has been more popular than the centrally fixed nozzle.



**FIG. 16: DOWNDRAFT GASIFICATION WITH CENTER NOZZLE AND AIR ENTRY FROM ABOVE**

### *CROSSDRAFT*

The principle of crossdraft gasification is shown schematically in Fig. 17. In this system it is endeavored to achieve a hearth zone of small volume but very high temperature, wherein the fuel's tar content is wholly gasified and the entire ashes converted to liquid slag. To this end, the air is introduced through a small diameter nozzle. The high air velocity (up to 80 m/sec) raises the temperature in the core of the hearth zone as high as 2000°. Across from the nozzle the gas passes through a grate into a filter.

The central hearth zone will cause the other zones through which the air passes to develop in a manner different from that of downdraft gasification, see Fig. 18. With the hearth zone as core, the distillation zone will assume a spherical shape, of which the part contacted by the gas stream will become the reduction zone. The drying zone reaches on the nozzle side to the bottom of the pegasus. The fuel serves as heat shield for the stack wall against the radiation from the hearth zone. The slag trickles in its liquid state

THE PEGASUS UNIT

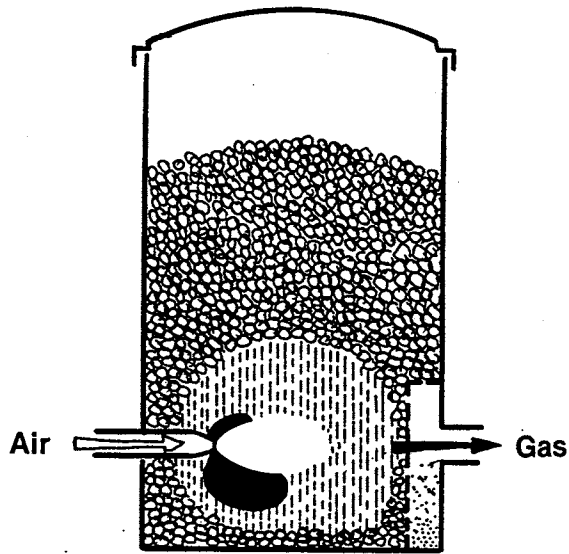

FIG. 17: CROSSDRAFT GASIFICATION

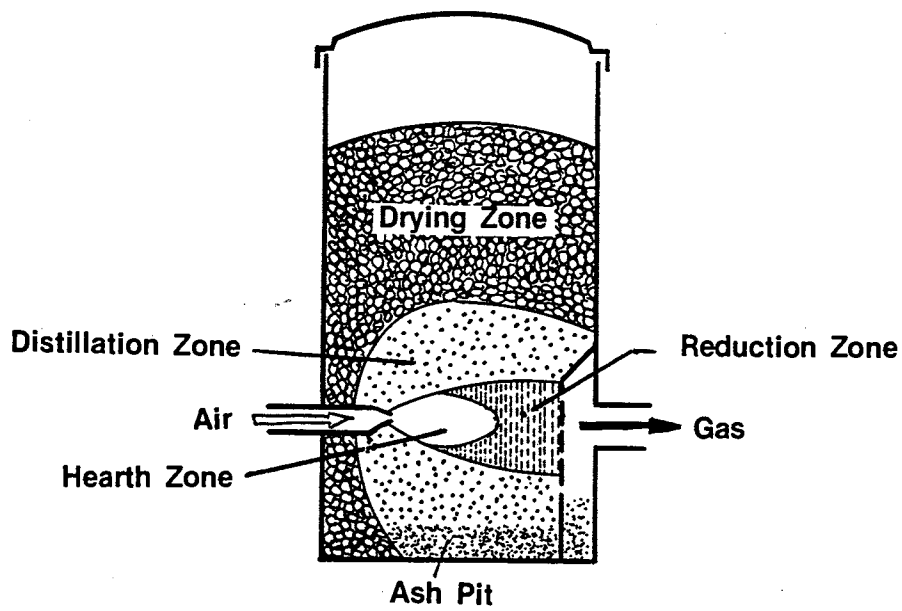

FIG. 18: ZONES IN CROSSDRAFT GASIFICATION

from the nozzle downward, but will also frequently solidify into a collar-like structure around the nozzle.

The small hearth zone enables the crossdraft system quickly to adjust to fluctuations in gas demand by the engine. It is flexible and needs little startup time when freshly loaded with fuel. But the small hearth zone requires a smooth and uninterrupted feed of fuel in reaction ready condition. If the fuel immediately adjacent to the nozzle has become degassed and slag encrusted from prior operation, the gas production can be affected in quantity and quality, and startup after temporary shutdown may be impeded.

Tar dissociation is naturally limited in the small hearth zone, so that crossdraft gasification is confined to low tar fuels. It is also desirable to use fuels of low ash content in order to keep the slag accumulation down. Slag removal from the hearth will then be necessary only at extended intervals, allowing long travel distances. It is apparent that trouble free functioning of a crossdraft system places heavy demands upon the fuel quality, limiting the choice to a relatively small group of fuels.

The gasification methods usable for the vehicle pegasus are summarized in Table 11.

**Table 11. Summary of Gasification Methods and their Uses in the Vehicle Pegasus**

PRINCIPAL FORM	DERIVATIVE FORM	PRIMARY USE WITH	
		Fuel	Steam Injection
Updraft Gasification	Diagonal Gasification	Low tar coke anthracite charcoal	Yes
Downdraft Gasification	Diagonal Downdraft Gasification	High tar wood peat lignite briquettes	No
	Crossdraft Gasification	Low tar and Low ash charcoal coke anthracite	No



**OTHER POSSIBILITIES**

As is evident from Table 11, systems have developed in the direction of updraft and crossdraft for fuels of low tar content, while downdraft is employed for high tar fuels, so that a pegasus type can be found which will satisfactorily handle any one of the entire range of fuel types. Further designs are possible, combining the principles of the three main types. For example, a combination of updraft and crossdraft can be used in stationary installations.

A variation on the downdraft type has been used as shown in Fig. 19. Here a single nozzle supplies the air, pointed diagonally downwards, so that the hearth zone develops from the tip of the nozzle. In some cases, the design incorporated a throat section in the hearth zone. This rather rare design is also suitable for fuels of high tar content, as ashes and slag can descend unobstructed to the bottom, but the arrangement requires careful nozzle placement to obtain tar free gas. It represents an intermediate stage between downdraft and crossdraft gasification.

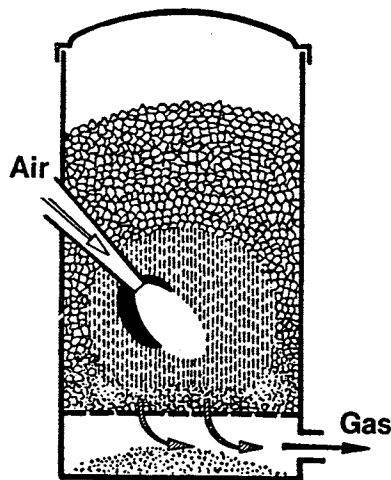

FIG. 19 DIAGONAL DOWNDRAFT GASIFICATION

# Chapter IX

## THE GAS

### COMPOSITION

After the sundry factors affecting the gasification have been dealt with in the previous sections, it is easily surmised that the pegasus gas as the end production of the processes also will show effects and variations from these influences. For this reason it is not possible to state a universally correct analysis of pegasus gas or to define the gas qualitatively with the certainty and narrow limits applying to gasoline or diesel oil.

It is to be expected, therefore, that in the composition of the pegasus gas larger variations will manifest themselves than in the composition of liquid fuels. It has been found that, depending on fuel and gasification method, the components will occur within the following limits:

CO (carbon monoxide)	20 to 30% (by volume)
H <sub>2</sub> (hydrogen)	10 to 25
CH <sub>4</sub> (methane)	0 to 4
CO <sub>2</sub> (carbon dioxide)	2 to 15
N <sub>2</sub> (nitrogen)	45 to 60

In contrast, the composition of other gaseous and liquid fuels used for automotive propulsion are fixed with the narrowest of limits.

For example—

Methane:	75% C and 25% H <sub>2</sub> (by weight)
Propane:	60% C and 25% H <sub>2</sub>
Gasoline:	85.7% C and 14.3% H <sub>2</sub>
Diesel oil:	86.4% C and 13.6% H <sub>2</sub>

The calorific value of the pegasus gas will lie between 900 and 1400 kcal/Nm<sup>3</sup> in accordance with the particular composition.

Since the gas composition reflects whether the gasification procedure functions properly with a given fuel and pegasus unit, the precise analysis is imperative in research and development work. It may be obtained during test stand operation by withdrawal and subsequent analysis of gas specimens, or by automatic analytical recording by sensors of the entire gas production during the test.

Some examples of compositions of pegasus gases from different fuels are given in Table 12. The results in the table only represent one gasification experiment, and no conclusions can be drawn about fuel or gasification procedure.

Gas analyses are important as a means of showing the

effects of changes in fuel, pegasus or gasification conditions in experimental work.

**TABLE 12—Examples of the Composition of Pegasus Gas Derived From Different Fuels**

Fuel	Gasification Method	Percentage by Volume					Measured Calorific Value kcal/Nm <sup>3</sup>
		Combustible			Non-Combustible		
		CO	H <sub>2</sub>	CH <sub>4</sub>	CO <sub>2</sub>	N <sub>2</sub>	
Wood (15% moisture)	Downdraft	22.2	17.5	0.8	12.2	47.3	1190
Wood (25% moisture)	Downdraft	23.0	14.1	0.9	16.0	45.9	1130
Charcoal	Updraft	30.4	19.7	—	3.6	46	1430
Peat	Downdraft	19.0	11.2	1.0	14.0	54.8	950
Lignite Briquettes	Downdraft	22.8	14.0	1.0	12.3	49.9	1140
Lignite Coke	Updraft	30.4	11.2	0.4	2.0	54.8	1280
Hard Coal Coke	Updraft	25.6	20.8	—	5.1	48	1350
Anthracite	Updraft	27.0	12.7	0.7	3.9	55.7	1200
	Crossdraft	24.4	8.9	0.6	2.8	61.9	1020

### CALORIFIC VALUE

The calorific value of the gas may be computed from the content of combustible constituents indicated by the analysis.

Example: Computation of the calorific value of pegasus gas derived from anthracite in updraft gasification using the data in Table 12.

1 Nm<sup>3</sup> of this gas contains:

0.270 Nm<sup>3</sup> CO of calorific value 3,020 kcal/Nm<sup>3</sup> = 804 kcal/Nm<sup>3</sup>

0.127 Nm<sup>3</sup> H<sub>2</sub> of calorific value 3,050 kcal/Nm<sup>3</sup> = 375 kcal/Nm<sup>3</sup>

0.006 Nm<sup>3</sup> CH<sub>4</sub> of calorific value 8,550 kcal/Nm<sup>3</sup> = 51 kcal/Nm<sup>3</sup>

0.404 Nm<sup>3</sup> combustible constituents ..... 1230 kcal/Nm<sup>3</sup>

The following values can serve as a guide to determine calorific value for purposes of general estimates:

Anthracite and coke, wet updraft gasification . . . . .	appr. 1300 kcal/Nm <sup>3</sup>
Wood, air dried, downdraft gasification . . . . .	1200 kcal/Nm <sup>3</sup>
Lignite, downdraft gasification . . . . .	1150 kcal/Nm <sup>3</sup>
Anthracite and coke, dry crossdraft gasification . . . . .	1100 kcal/Nm <sup>3</sup>
Wood, 25% moisture . . . . .	1000 kcal/Nm <sup>3</sup>
Peat, air dried . . . . .	900 kcal/Nm <sup>3</sup>

One is generally inclined to consider calorific value as the strongest indicator of the quality of the gasification. This is only partially justified. To be sure, a high calorific value of the pegasus gas does testify to a successful transferral of energy from the fuel to the gas and thereby indicates a good efficiency of the gasification. But the practical functioning of the pegasus vehicle depends not only on the amount of calorific value but also on the uniformity of the gas composition with its resultant calorific value. This is because the admixture of combustion air to the gas constantly must be so adjusted as to attain the best engine performance. Since these adjustments always have been made by hand by the driver, any change in gas composition and in calorific value requires manual intervention to achieve careful readjustment. This necessitates constant attention and increases the operating cost of the vehicle. The work is unavoidable, as fluctuations in the quality of the pegasus gas are inevitable, particularly when variations in gas demand occur as a result of changing traffic conditions.

A certain variability in the calorific value can also be observed when the gas demand is kept constant as on a test stand, and it is caused by changes in the hearth zone, formation of ashes and slag, temporary obstruction of the air stream by ash formation or grain breakdown, etc., any and all of which continually give rise to minor changes in the gasification conditions. It is not usually necessary to adjust for these small variations as they tend to cancel each other out.

Changes in calorific value may also occur over the entire gasification range, arising from the degassing process which transfers to the gas a high proportion of volatiles of high calorific value.

For example, anthracite shows a characteristic maximum in calorific value about 45 minutes after starting, which is clearly attributable to the released volatiles, see Fig. 20. This maximum occurs both in updraft and in crossdraft gasification and can be

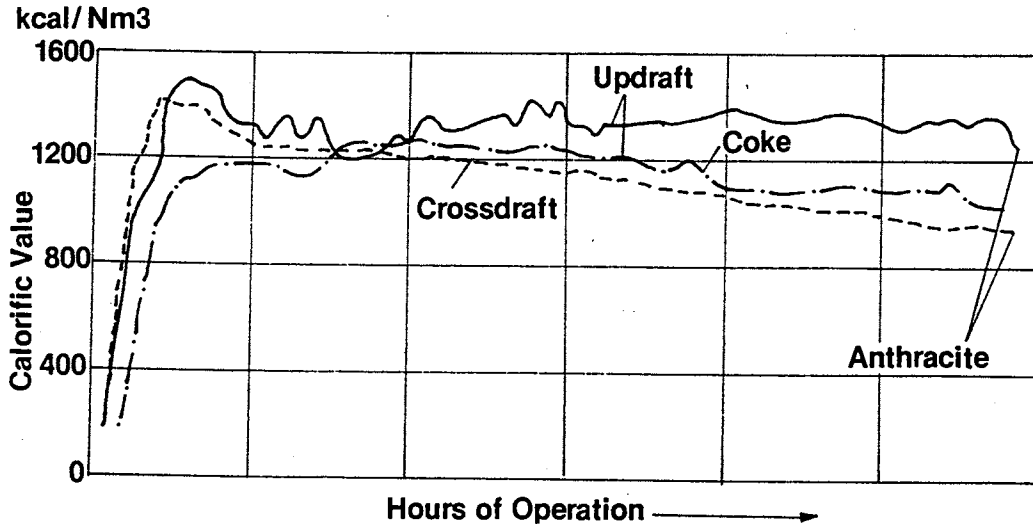

FIG. 20: GRAPHS OF CALORIFIC VALUES OF VARIOUS FUELS AND GASIFICATION SYSTEMS, AS FUNCTIONS OF TIME

proper adjustments cause a corresponding maximum in engine performance. The further behavior of the calorific value graph does, however, show differences between the two gasification methods. Whereas the updraft system delivers a gas of almost constant calorific value, there is a noticeable drop when the crossdraft system is used. The cause is gradual slag formation in the nozzle area, making appropriate draft regulation essential. With severe slag formation the calorific value may finally reach a value so low that operation becomes impeded and slag removal is unavoidable. Coke does not show a graph maximum, as it is already a degassed fuel. The graph instead levels off more slowly.

It is thus apparent that it is of more practical value to emphasize uniformity in calorific value of the gas output, rather than maximum values, in order to facilitate the functioning of the system.

There is usually an immediate improvement in calorific value after a shakedown of the fuel column, and this is particularly true for lignite briquettes. This is so because the ash film covering the fuel grains is broken, affording new ignition points for the gasification.

#### QUANTITY

The quantity of gas to be extracted from one kg of fuel varies with both fuel type and gasification method used. The average values are shown in Table 13.

**Table 13. Gas Production from one kilogram of various fuels:**

wood .....	approx. 2.3 m <sup>3</sup>
lignite .....	4.0 m <sup>3</sup>
lignite briquettes .....	3.2 m <sup>3</sup>
hard coal coke .....	3.6 m <sup>3</sup>
anthracite .....	4.5 m <sup>3</sup>

### *TEMPERATURE*

The gas leaves the stack at a temperature of 300°-500°, the higher limit applying at full throttle operation. If the temperature rises higher than 500° it can be taken as an indication of incomplete gasification or partial combustion of the gas with unused air in the stack. This sensible heat in the gas represents an energy loss, unless it is utilized to heat the combustion air or the injected steam. Cooling of the gas by these means is usually insufficient and further heat removal in the cooler is necessary.

## Chapter X

# DESIGN OF A VEHICLE PEGASUS

### GENERAL SYSTEM CONSIDERATIONS

The vehicle pegasus should ideally convert the solid fuel, at a minimal energy loss, into combustible gas. The gas must in turn reach the engine in filtered and cooled condition. It should be realized, however, that the vehicle pegasus functions under difficult

**Table 14: Requirements in Automotive Pegasus Design**

REQUIREMENT	REASON
High gas yield	Low weight. High engine performance. Good economy.
Pure gas	Protects pegasus and engine from corrosion and premature wear, improving economy.
Flexibility in meeting gas demand	Reduced operating expense. Good vehicle adjustment to traffic flow. Improved economy
Operating readiness	Short startup and warmup. Swift increase in gas production from start to full load.
Low weight	Minimal reduction in useful vehicle load. Low purchase cost.
Small size	Minimal reduction in usable loading volume.
Simple construction	Trouble free, simple to operate, fool-proof.
Low sensitivity to fuel type	Greater independence. Protection from fuel supply difficulties. Economy.
Low maintenance	Better economy. Reduces maintenance errors and omissions.
Common design	Low production cost, interchangeability.
Non-polluting	Social responsibility to avoid harmful emissions.
Safe re: fire, explosion, toxic fumes	Safety always of high priority.

circumstances as compared with stationary installations. The reasons for this are the special requirements which must be met to the greatest extent possible. They are summarized in Table 14.

The requirements cannot be met by the pegasus alone but demand a proper balance between pegasus and fuel. Close observation of pegasus types and design details reveals numerous ways in which the requirements can be accommodated, no matter how difficult they appear.

Several designs were mass produced in Germany prior to and during World War II, usually as fully assembled units attachable to the common vehicle models of the day, but components were also widely available to enable the user to custom assemble an installation.

Through the multiplicity of requirements and designs runs a common approach, and the layout in Fig. 21 shows the resulting typical system.

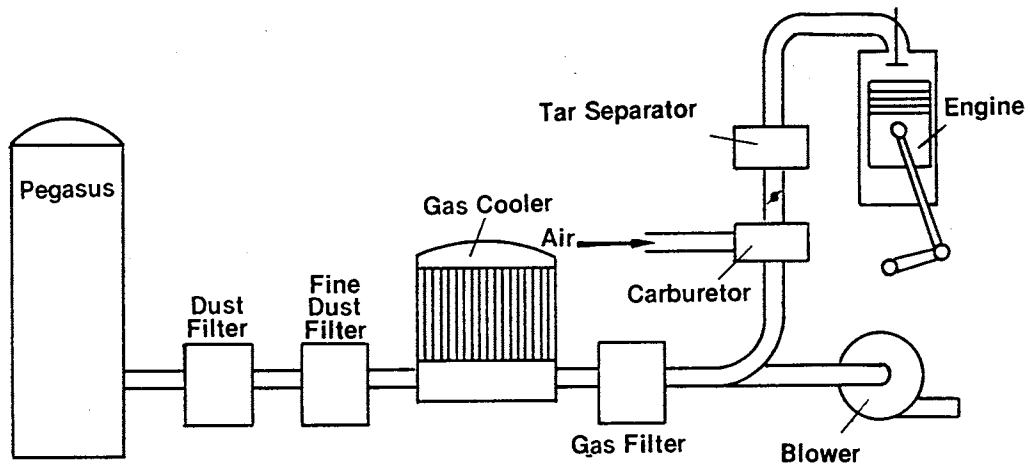

FIG. 21: BASIC SYSTEM LAYOUT

From the pegasus, the gas goes first to a primary dust filter where coarse particles of fuel and ashes are removed. A secondary filter subsequently removes the finer dust, and the gas goes to a cooler where its temperature is dropped below the dew point. This removes the steam content and the gas now passes through a gas filter in which remnant steam and some gasified tars are arrested. The gas proceeds to the carburetor to be mixed with air in the proper ratio, and the gas-air mixture is passed through a final tar separator before entering the engine's cylinders. Before the carburetor a branch



is provided for the starting blower.

We shall now proceed to look more closely at the pegasus unit itself as well as the various other components needed to make the system complete, balanced and well functioning.

### *THE PEGASUS UNIT*

*The Stack.* An automotive pegasus unit consists of stack, hearth, grate and ash pit. The unit is almost invariably cylindrical in shape, the upper part serving for fuel storage and the lower part comprising hearth with air entry and grate. Rectangular and square cross sections have also been used with the advantage of space savings when incorporated into a cab, but these shapes are subject to greater temperature stresses unless very carefully designed.

Fig. 6 shows a World War II pegasus of Imbert design. The housing encloses the items named above, and the gas outlet is at the top. The stack can be welded integrally into the housing or can be detachably suspended.

Deviation from a simple cylindrical stack of uniform diameter is only justified when the cylinder shape would lead to excessive height. It is possible to reduce height by enlarging the cross sectional area of the upper stack, the fuel storage volume. It is then important to keep the taper between the upper and lower sections less than the fuel's natural angle of repose to assure a steady feed.

Some designs have a single-wall stack, but many endeavor through a double wall arrangement to use the heat content of the raw gas to pre-heat and dry the fuel column by passing it through the space between the inner and outer walls, see Fig. 6. The inner wall should be corrosion resistant to withstand the effects of the distillation products, particularly acetic acid.

In a simpler design of the wood fueled pegasus, the inner stack is perforated to allow steam and distillation gases to escape rather than enter the hearth zone, see Fig. 35. They will condense in the inter-wall space from the cooling effect of wind on the exterior wall and are collected in a container from which they can be periodically drained. This type never gained popularity, as only a modest fraction of distillates was extracted from the fuel, and the corrosive liquids caused frequent leakage.

The updraft pegasus with circumferential gas exit is usually given a funnel shaped constriction above the hearth zone, see Fig. 22, to provide for the gas a collecting space in which part of the dust content can settle out. This also prevents heating and distillation in the fuel column located above the constriction.

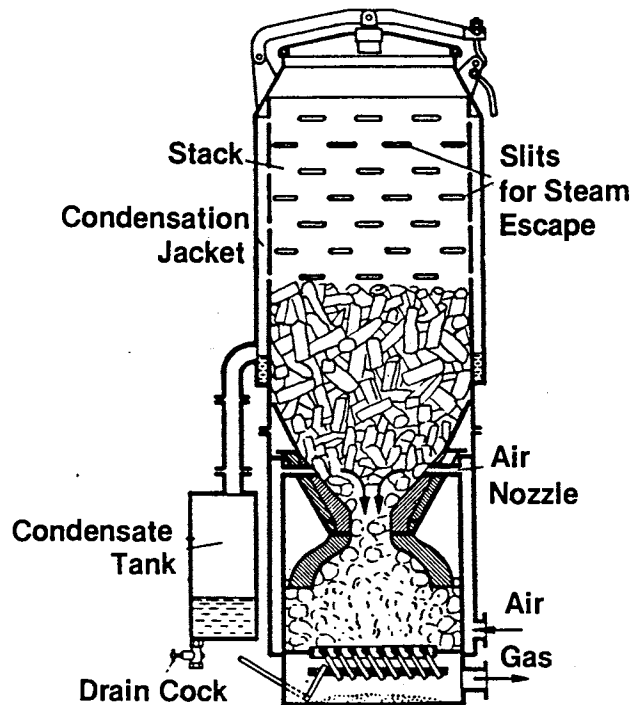

FIG. 22: PEGASUS WITH CONDENSATION JACKET

*Sliding Gate.* Some designs have incorporated a sliding gate to separate the fuel column from the hearth zone, retaining the fuel above during slag removal, as shown in Fig. 23. The gate is inserted from the outside, a difficult operation at best, and adequate air tightness of the insertion slot is a problem. This can be avoided when the gate is inserted through the slag removal door.

*Cover.* Minor explosions may occur when air enters the gas saturated fuel column, and it is therefore advisable to let the stack cover serve also as safety valve. This can be arranged by using a spring loaded lever as shown in Fig. 24. This will allow the cover to open sufficiently when enough pressure is applied from below. In the design shown in Fig. 25 a plate spring provides a double safety valve

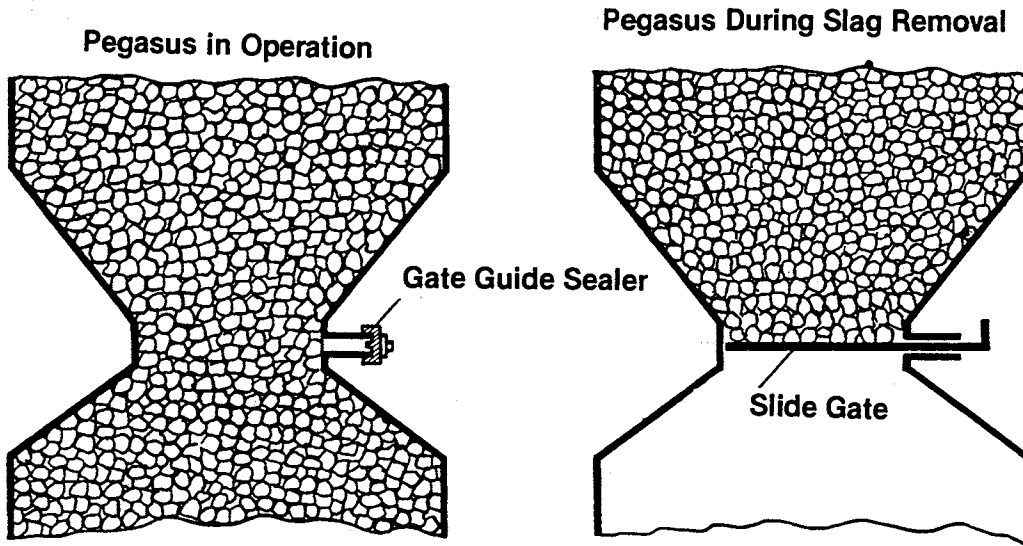

FIG. 23 SLIDE GATE TO CLOSE HEARTH GATE FROM STACK

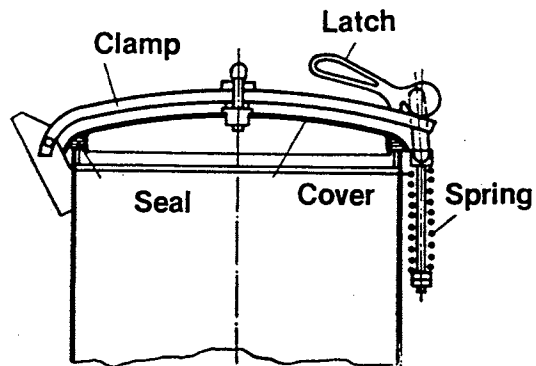

FIG. 24 SPRING LOADED LATCH AS SAFETY VALVE ON STACK COVER

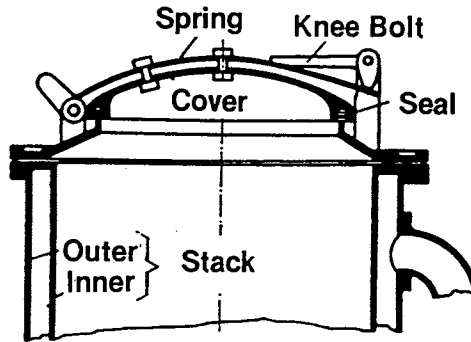

FIG. 25 STACK COVER LOCKING WITH DOUBLE VALVE ACTION

effect, allowing a small lifting of the cover by minor pressure from below and total opening when high pressure activates the release lever.

*Hearth and Grate.* In updraft gasification the hearth zone is usually a section of the cylindrical stack, which is lined with refractory material, as shown in Fig. 26. The lower limit of the hearth zone is the grate through which ashes and slag move down while air and steam flow upwards.

Some fuels will endanger the lining by forming slag that bakes onto the refractory material. The deposit has an adverse effect on the gasification process by reducing the cross sectional area, and

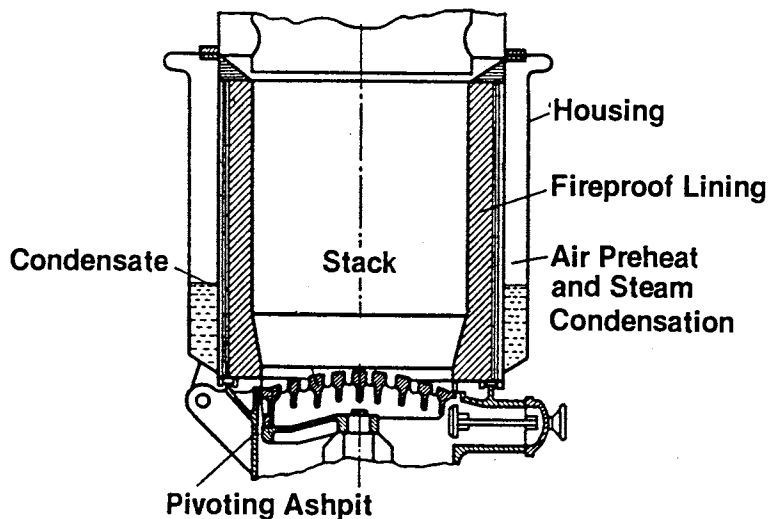

FIG. 26 HEARTH IN AN UPDRAFT PEGASUS

removal may cause damage to the lining. None of the refractory materials used in the past has been repellent to all slag types. Since a cool lining is less susceptible to slag deposit, prevention of the deposit is best achieved by using refractories of high heat conductivity, by keeping the lining thin, or by providing exterior cooling. Use of a poker presents another threat to the lining and should be avoided.

Crossdraft gasification permits the hearth zone simply to develop from the nozzle through the center of the fuel column, see Fig. 17. The grate is located outside the hearth zone and has as its primary purpose to contain the fuel and slag. The latter flows in a molten state downwards and is removed through a cleanout door.

Downdraft gasification presents the greatest variety of design, and both metal and refractories have been used as wall material. The Imbert system shown in Fig. 6 has a hearth of alloy steel, whereas the Stinnes system uses a refractory lining of the hearth walls, see Fig. 49. The metallic version is usually a stainless alloy, giving the advantage of light weight, flexible adjustment to fluctuating gas demand and quick startup. Severe temperature changes may warp the metal hearth walls, causing ruptures, gas leakage and incomplete dissociation of tar and acetic acid.

Refractory hearths take longer to warm up due to their poor conductivity and are also heavier than metal hearths. On the other hand, they maintain the hearth zone temperature longer during shutdown, improving restarting.

All hearths for downdraft gasification have the constriction

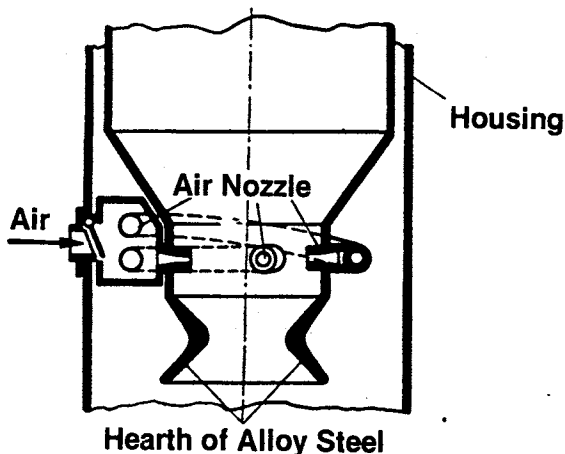

FIG. 27: FOR GASIFICATION OF WOOD

in order to reach the high temperatures necessary for tar dissociation. To this end, metal hearths should be cast or fabricated from suitably heat resistant alloys and welded into the lower stack, see Fig. 27. The air nozzles should be located above the constriction so that the air velocity reaches maximum in the constriction. This arrangement is only usable with fuels of low ash content, as otherwise the constriction will be blocked by slag formation.

A proper balance between constriction and gas demand is important for trouble free operation, and to some extent also for engine performance. Rather than being formed by the hearth wall, the constriction can also be created by inserting a throat plate, i.e. a plate of a heat resistant alloy with an opening of the proper dimension. This has the obvious advantage of exchangeability of the part exposed to the most intense heat, but it also permits adjustment of the throat opening by insertion of a plate of different opening diameter, see Fig. 28. If the throat diameter is too large, the pressure drop will be insufficient and the tar will not be fully dissociated. Conversely, if the throat diameter is too small, the pressure drop will be so severe as to impede engine performance, although tar free gas will be assured.

Fig. 29 shows a design of a semi-spherical hearth enclosing the air nozzle. The hearth is cast from a heat resistant alloy, and the distance between nozzle and throat is somewhat adjustable, thereby

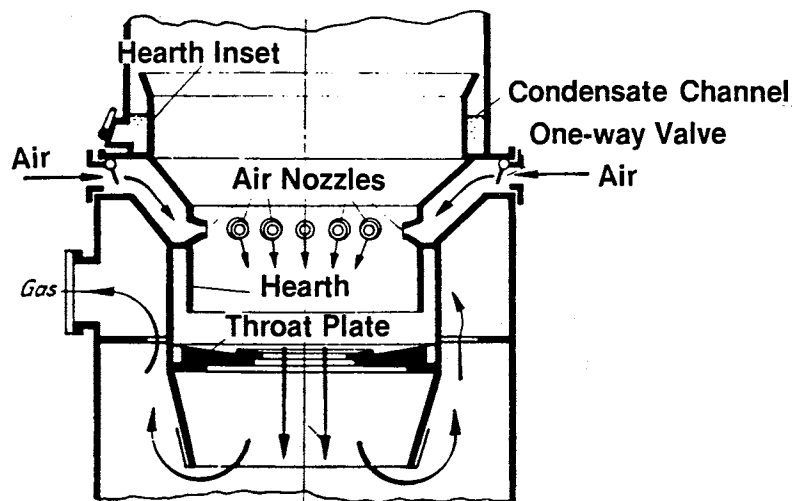

FIG. 28 HEARTH WITH THROAT PLATE

effecting some temperature control. This arrangement has been used in automotive systems for short-distance operation, in which the time may not allow full hearth temperature to be reached without such adjustment.

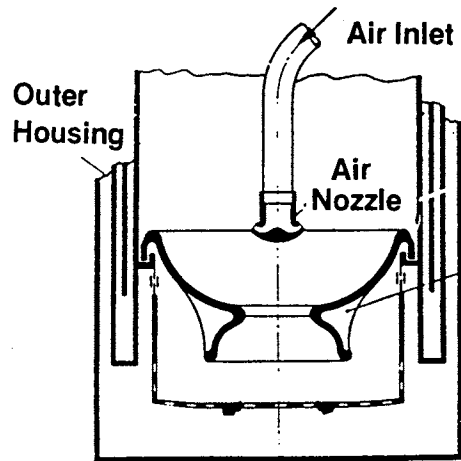

FIG. 29: SEMI-SPHERICAL HEARTH FOR DOWNDRAFT GASIFICATION

As alloy metals were scarce in Germany during World War II, ceramic hearths gained popularity, particularly for gasification of lignite briquettes. As shown in Figs. 30 and 31 the shape closely approximated that of metal hearths, and when a high grade of workmanship was applied to avoid stress fissures, the ceramics worked well. Ceramic hearths actually excel in their ability to withstand prolonged high temperatures.

*Grate.* Beside supporting the fuel column, the grate serves in

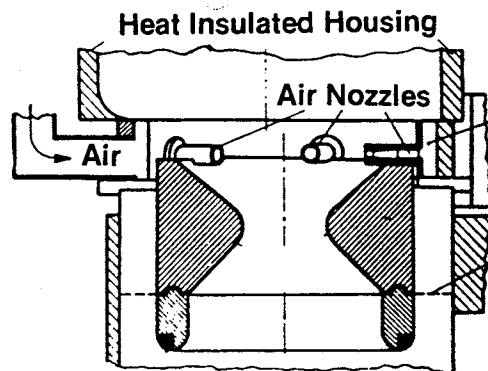

FIG. 30 CERAMIC HEARTH

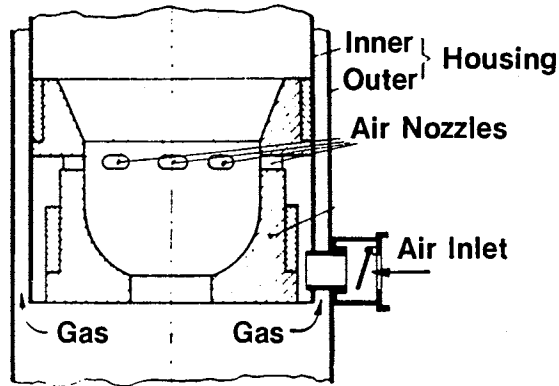

FIG. 31 CERAMIC HEARTH

downdraft systems to retain unburned fuel particles, whereas in updraft systems it distributes the air flow over the hearth zone.

To facilitate detachment and separation of ashes, the grate is so constructed as to effect a shakedown and aeration of the burning fuel in the hearth zone, see Fig. 32. This can be accom-

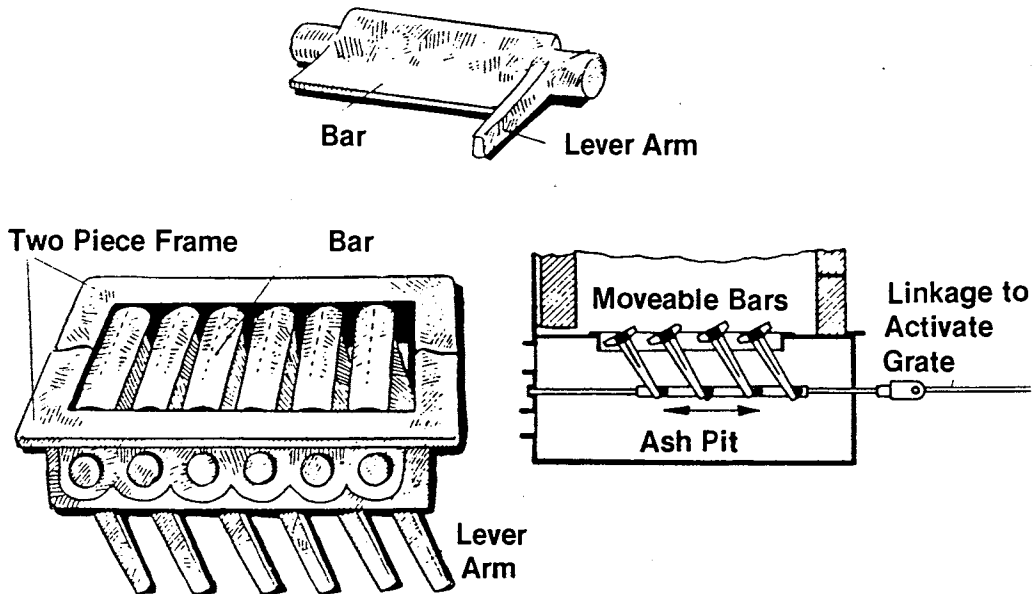

FIG. 32 GRATE WITH INDIVIDUALLY MOVING BARS



lished by the shaking movement of the grate, but it may be reinforced by a number of pegs attached to the grate and protruding into the hearth zone, see Fig. 33. The shakedown can be done through a linkage arrangement operated by a handle at the driver's seat. Systems have been built in which the shakedown is power driven and

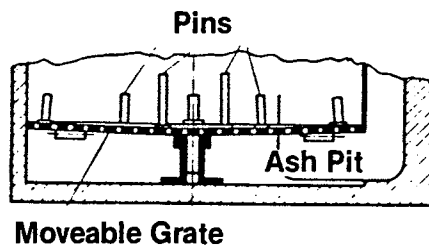

FIG. 33 GRATE WITH PINS

automatically activated to remove ashes and slag, see Fig. 34, enabling the pegasus to burn fuels of high ash content. Some additional weight must of course be accepted in such layouts.

Grate trouble arises chiefly from sticking or "freezing" due to warping or deformation by the high temperatures, but prevention is not difficult.

Cleanout can be greatly simplified by careful design. The stacked grate in Fig. 10 and the moveable grate ash pit combination in Fig. 26 are cases in point. Total elimination of the grate is feasible, as shown in Fig. 35. In this case the fuel column is supported directly by the floor of the stack, and the air distribution becomes somewhat inferior.

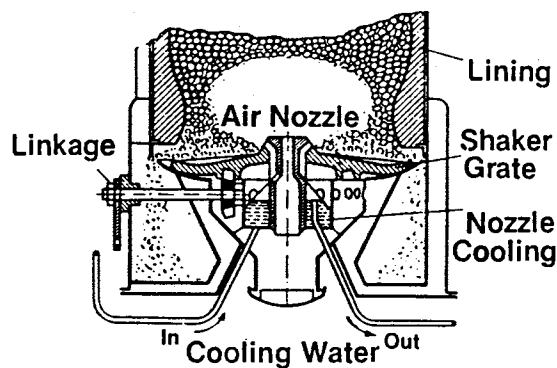

FIG. 34 SHAKER GRATE

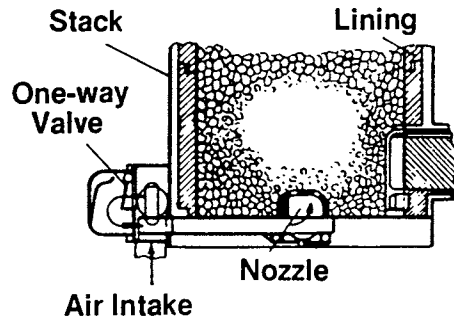

FIG.35 HEARTH IN AN UPDRAFT PEGASUS WITHOUT GRATE

*Air Intake.* The pegasus air intake is virtually always done through a one-way valve, see Fig. 38, which is actuated by the partial vacuum in the stack. If the stack pressure momentarily rises, as when the engine suction ceases or if a small explosion occurs, the valve shuts and prevents the escape of gas. A flame arrester may additionally be fixed in the valve to prevent flame escape.

*Gas Exit.* In downdraft and crossdraft systems the gas can only find exit above the grate. Some downdraft types have been built with gas outlet approximately at hearth level, as in Fig. 28, but usually the gas is led up between double walls of the stack as in Fig. 6 for the purpose of pre-drying the fuel column. Some settling-out of heavy dust particles is also achieved.

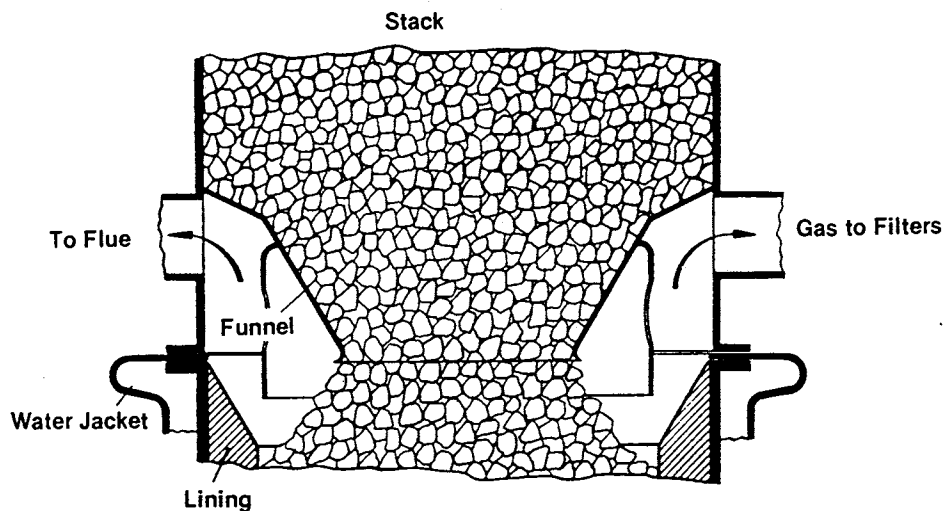

FIG. 36 FUNNEL SHAPED CONSTRICTION OF STACK FOR CIRCUMFERENTIAL GAS EXIT

In updraft systems the gas is usually drawn off near the midpoint of the stack to avoid distillation of the entire fuel column, see Fig. 12. Two designs will further this end. In one the fuel column is pinched by a constriction, see Fig. 36, to create a ring shaped gas collection chamber. The other provides a gas exit funnel above the distillation zone below which a small pocket will form a collection chamber, see Fig. 37. The funnel creates a reduction in cross

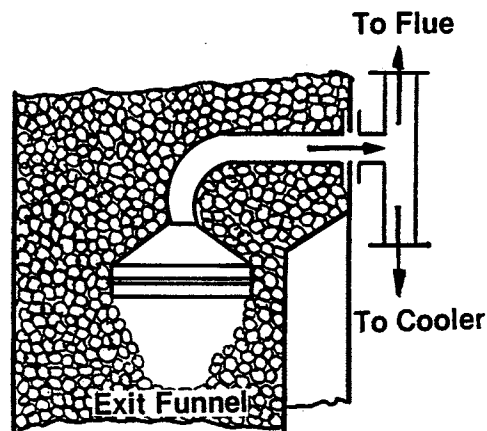

FIG. 37 GAS EXIT FUNNEL IN UPDRAFT SYSTEM

sectional area, as does the constriction, and in either case the fuel column above is partially supported thereby, thus preventing undue compression of the hearth zone's fuel charge.

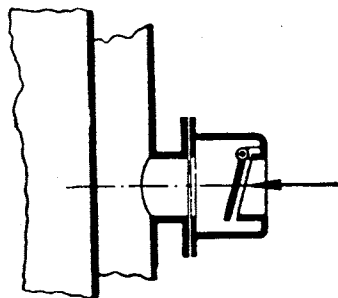

FIG. 38 ONE-WAY VALVE TO AIR INTAKE

### THE AIR STREAM

Two different principles can be employed to feed the air stream into the hearth zone. One principle involves the entry of air jets through one or more nozzles, the other simply distributes the air broadly through the grate into the entire hearth zone.

The latter method is only feasible in updraft system. It has the advantages of preheating the air by filtering through the ashes on the grate, and of requiring no special injection apparatus. Fig. 26 illustrates this method. The most common method in downdraft and crossdraft systems is that of positioning one or more air nozzles at the fringe of the hearth zone. In downdraft the nozzles are usually circularly arranged, the air being supplied to each either through an individual pipe or through a common ring shaped feeder line, see Figs. 28 and 39. The nozzles will in these cases need no cooling, unless they are used in gasification of fuels requiring very high temperature.

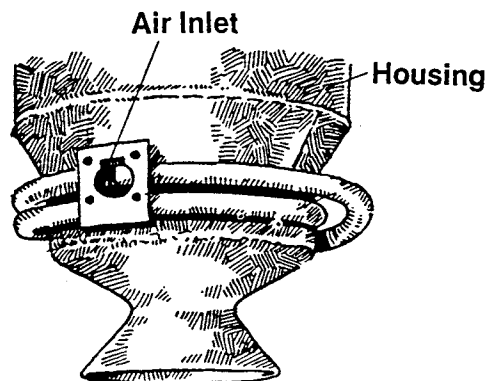

FIG. 39 AIR FEEDER RING FOR CIRCULARLY ARRANGED NOZZLES

A single nozzle is preferred in crossdraft gasification. It requires special cooling when high temperature fuel such as anthracite is gasified. The common solution is a water jacket as shown in Fig. 40, with a supply pipe leading water to the nozzle where it is heated and moved on in the circuit by gravity. The cooling water may be led to a radiator before being circulated again to the nozzle, or it may be taken from the storage tank for water used in the steam injection. In either case it is necessary to add antifreeze for winter operation to avoid frost damage.

The shape and dimension of the nozzle tip will determine the air velocity and hence the temperature of the hearth zone. It is

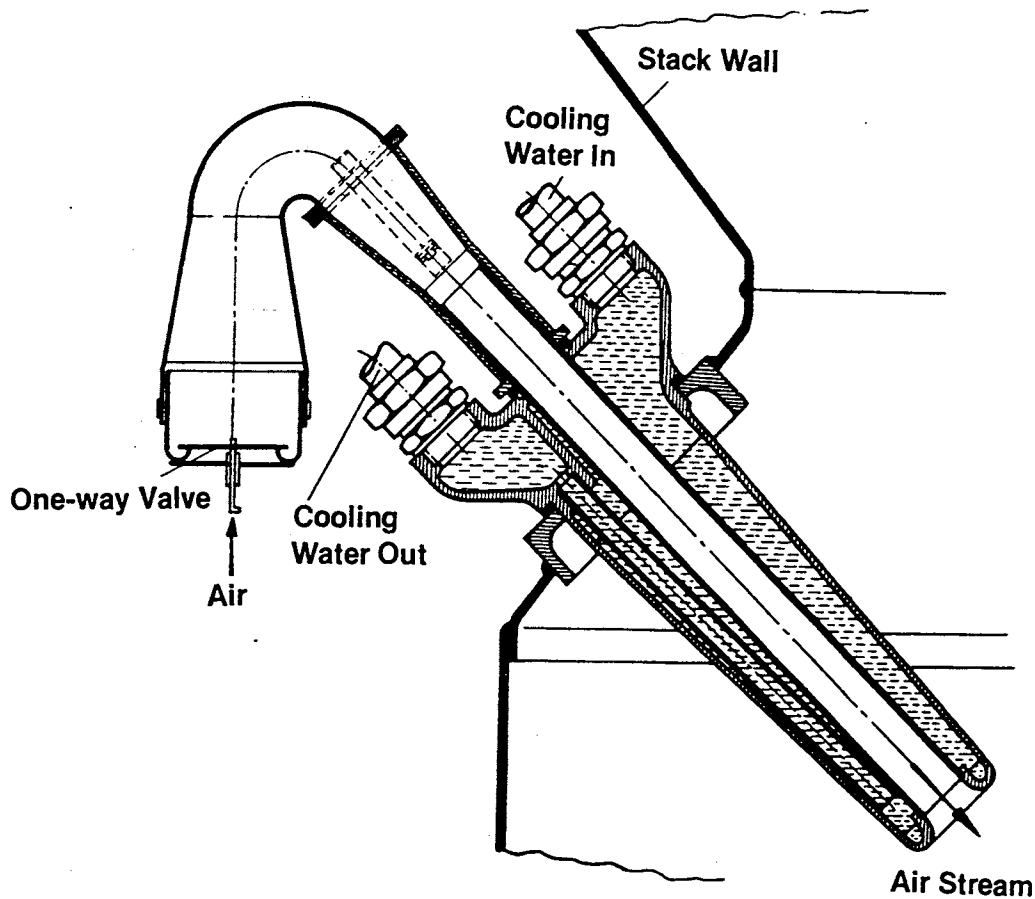

FIG. 40 WATER COOLED NOZZLE FOR CROSS DRAFT SYSTEM

possible to adjust these parameters to attain optimum gasification conditions in any given case by using nozzle inserts to change the cross section of the nozzle opening. Not only the area but the nozzle shape, i.e. circular or rectangular, influences the gasification processes.

Placing a secondary or supplementary nozzle, aimed in the direction of the slag runoff, has been used in some designs. This will facilitate both the slag flow and the ready descent of fresh fuel, see Fig. 43.

When high-response fuel such as lignite briquettes is used in diagonal downdraft systems, special nozzle cooling is superfluous. This is desirable in automobile systems, where weight is an important consideration. Nozzles of cast iron or alloy steel will usually stand up well.

If a control nozzle is chosen it can be placed at the limit of the hearth zone, needing no cooling system. Updraft is suitable, as the descending ashes will protect the nozzle against excessive heat. The shape and size of the bed surrounding the nozzle can often be improved by a quantity of refractory lumps placed in the bottom of the stack. A typical center nozzle is shown in Fig. 35, where a basket design is used. The center nozzle is also used in downdraft gasification with air supply entering from above, see Fig. 29.

In order to improve the heat budget of the pegasus it is normal to preheat the air stream from the heat content of the gas or by radiation from the hearth zone. If the former source is used, the pegasus will be equipped with heat exchangers just beyond the gas exit, see Fig. 52. When the latter source is exploited, the air stream is led around the wall of the stack, cooling this in the process, see Fig. 6.

Air intake may in a simplified version take place through slots in the stack, see Fig. 22.

### *STEAM INJECTION*

Production of steam for injection is done in essentially the same manner, by drawing heat from the gas leaving the stack and by utilizing the heat radiation from the hearth. The water tank is often situated in the upper part of the stack as a water jacket for the purpose of preheating, see Fig. 51, but progressive heating of the water in a channel spiraling around stack and hearth is also common. The steam automatically enters the air stream as this is drawn through the steam chamber.

The quantity of injected steam must be carefully adjusted to the momentary gas load on the system. This can of course only be approximated, as there is some delay in the effect of changes in the water flow. Difficulty is particularly apparent at startup, as the hearth zone is functioning well before the steam production has gotten established.

Regulation of steam injection has at times led to rather elaborate potentially troublesome apparatus. It was therefore in many designs deleted altogether. The water flow is then simply set to give the optimum steam production when the engine runs at full load, and it is necessary to accept the disadvantage of excess steam at lesser loads, resulting in some moisture content in the gas.

When the evaporation takes place in a water jacket enveloping the hearth, the steam production can in some measure be regulated through a float. The right surface area can by this means be exposed to the momentary heat radiation to give maximum hydrogen content in the gas and avoid excess moisture, see Fig. 41. But this type of setup also entails a certain delay in steam production, so that overheating of the grate is a possibility. To offset this risk, an evaporation pocket can be built in as shown in Fig. 41. It is placed at the hearth zone and the thin wall of the pocket permits quick heat transfer, see also Fig. 50. Steam is generated at the very outset and grate overheating avoided.

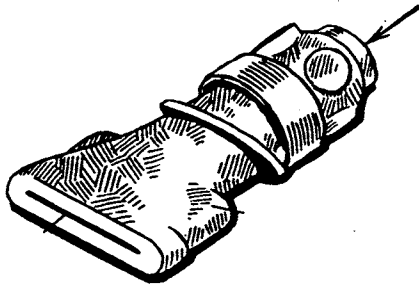

**Fig. 41 WATERCOOLED RECTANGULAR NOZZLE FOR CROSSDRAFT GASIFICATION**

The problem of steam injection is solved most simply by using the engine exhaust as shown in Fig. 42. The exhaust constituents of steam and carbon dioxide are dissociated in the hearth zone, and the dilution of the air stream with exhaust causes a drop in the oxygen content. All of these processes tend to lower the hearth temperature and the strain on hearth materials.

#### **AUXILIARY COMPONENTS**

In order to appreciate the need for system components to treat the raw gas, let us briefly reiterate the overall requirements to the system. In order to gasify the volatiles and the carbon, the vehicle pegasus must do the following:

- Deliver tar-, acid- and dustfree gas;
- Attain high calorific value of the gas;
- Reduce energy losses to the lowest possible level;
- Be flexible in adjusting to changes in gas demand;
- Keep high thermal efficiency and insensitivity to fuel quality;
- Possess ability to function on different fuels;
- Be simple to operate, easy to clean, quick in startup, accessible for repair;
- Display durable construction and resistance toward failures from vibration;
- Show light weight and small size.

Experience with many design types and thousands of units has been accumulated in times past, so that the essentials of pegasus technology can be stated with assurance.

An entire pegasus system comprises—

Pegasus unit  
Filtering apparatus  
Gas cooler  
Carburetor  
Blower (for starting)

and we shall discuss the components in that order.

*Filtering Apparatus.* When the stream of hot gas leaves the pegasus, it carries with it dust particles of ashes and unburned fuel. This dust must not reach the engine, as it would then combine with the oil and cause contamination and wear.

Fossil fuels also spawn chemical contaminants from their content of sulphur, silicon, tar and water. To avoid engine damage it is essential to remove both dust and tar.

Three filter types are used to separate dust from the pegasus gas before it enters the engine, and they are classified as dry, moist and wet in accordance with their principles of functioning.

In the dry category are the cyclone separator and the cloth filter. The cyclone is used to extract coarse or heavy dust particles and is the simplest and most robust separator to use. Having no moving parts, it works on the principle of separating the heavier-than-gas particles by means of centrifugal force.

The cloth filter, which was used in the Daimler-Benz system, is only suitable for very dry gas, as moisture will render the cloth virtually impermeable to the gas flow, stalling the engine. When



cloth filters are used, the gas temperature must be maintained well above the dew point, i.e. the temperature at which condensate will form in the gas. It is best to avoid this filter type.

The so-called moist filter receives its moisture as water condensate from the gas itself. This type is used in the Imbert system and in other wood fueled pegasus units. The gas is led through the condensate, being in the process somewhat cleansed and cooled.

In the wet filter the gas is actually washed in water. Both dust and some chemical contaminants are in this manner arrested in the water. The method is well suited for fossil fuels such as anthracite and charcoal.

Most new pegasus gas contains some tar, which can form deposits in pipes, carburetor and engine unless carefully removed. Some tar emulsions will remain fluid after cooling to room temperature, while others will solidify. The former derive chiefly from fossil fuels and are fairly harmless to the engine. The latter are usually contained in wood gas, particularly when the pegasus system for some reason is malfunctioning. The solidified tar deposits will then gum up valves and suction piping so that serious trouble is in the making.

The tars cannot be removed by cooling alone, as the dew point of the gaseous tars depends on the partial pressures of the tars and is very low. It is therefore necessary to use fuels with the lowest possible tar content.

In wood gas production care must be taken to maintain a high (700°-900°) temperature in driving at high r.p.m., and attention must be paid to the condition of the hearth, inspecting for cracks and deformation. The tar content of the wood gas should thereby be kept under 1 g/m<sup>3</sup>. It is essential to cool the gas sufficiently, i.e. to about 40-45° to condense the steam before it reaches the engine. If the gas temperature is too high, too small a mass of gas will enter the cylinders.

*Gas Cooler.* The purpose of the gas cooler is to bring the gas temperature below the dew point to condense the steam without delay. In vehicle installations the gas cooler is usually mounted in front of the radiator, and it is equipped with a drain cock so the water can be drained from time to time. The cock must be kept well closed,

as the engine's suction can be easily impaired by minor leaks at such points.

*Blower.* During startup the blower replaces the engine suction in moving the air stream through the hearth zone. When the gasification is going well, the blower can be turned off and the engine started. The engine's suction then takes over as motive power for the air stream/gas stream through the system, see Fig. 6.

The blower consists of an impeller wheel, housing and a small electric motor.

#### MISCELLANEOUS

All systems have doors or hatches that can be tightly closed and which serve to facilitate ignition when this cannot be done through the air nozzle. Other openings allow slag and ash removal, see Fig. 43. The precise location of the service openings is governed by the hearth design, the gasification method employed and the fuel.

To enable the pegasus to function at an idling level with the engine shut off, thereby permitting quick restarting of the system, some designs incorporate a flue which is branched off just after the gas outlet from the stack, see Fig. 39. The slight draft from the flue lets the stack function as a stove, keeping the hearth's coal bed glowing.

The flue also serves as a test pipe for the gas being produced by the blower action just prior to startup. The flue should be furnished with a one-way valve, which is kept closed by the engine suction after startup.

## Chapter XI

### SOME SYSTEMS OF THE PAST

On the following pages are schematic drawings of some of the systems developed and used prior to and during World War II. Some of them survived briefly in isolated or underdeveloped areas of the world, but they are largely unknown to the engineering community.

In Fig. 42 is shown a Deutz system for dry gasification using the updraft principle. Notice how part of the exhaust gas is recirculated through the stack. The flue has a manually operated valve where the gas can be tested for combustibility during startup.

Fig. 43 shows a Henschel layout featuring diagonal cross-draft through a single nozzle. It is equipped with a water jacket enclosing the upper part of the stack which serves as fuel storage chamber. Water is supplied from the jacket to cool the nozzle, and steam is drawn off the top of the jacket, led to the ash pit, and mixed with the air stream. The grate can be shaken by lever action from the driver's seat.

It should be noted that the cooling water for the nozzle circulates by the thermal-gravity effect of differential heating, needing no pump. The steam injection likewise occurs by naturally generated pressure without auxiliary gadgetry.

The Zeissl installation shown in Fig. 44 uses updraft from a centrally placed, downwards pointed nozzle. Tandem centrifugal dust collectors are used, as well as tandem filters for secondary cleaning of the gas after cooling.

The complete installation loaded with fuel weighs 575 kg, broken down as follows: stack 200 kg, fuel 160 kg, and auxiliary components (filters, cooler, blower, etc.) 215 kg. This pegasus functioned on briquettes and/or wood.

A different type is shown in Fig. 45. This is a Grunert system, designed to burn anthracite and coke. It features updraft and steam injection, and the air enters through slots in the stack wall.

Grunert produced three models yielding 90, 150 and 220 Nm<sup>3</sup> of gas per hour. They weighed, fully fueled, 510, 655 and 1000 kg, and were obviously for truck and tractor adaptations.

The Zeuch installation in Fig. 46 has the characteristic ring of nozzles feeding air into the hearth zone, the air being preheated in a ring-shaped chamber on which the nozzles are mounted. The hearth is equipped with a replaceable throat plate constricting the air stream and aiding the gasification processes in the hearth zone. The air is drawn down through the grate and off to the centrifugal dust collector, heating the ring shaped nozzle chamber on the way.

Mercedes-Benz produced pegasus installations for both cars and trucks during World War II. Fig. 47 shows a car pegasus with cross draft. It is designed to burn charcoal and lignite briquettes, with a gas producing capacity of  $120 \text{ Nm}^3/\text{hr}$ . This makes it suitable for cars from 0.5 liters to 3.0 liters volume. The nozzle diameter must correspond to the engine size of the particular car using the pegasus.

A larger installation is shown in Fig. 48. It features cross draft from a diagonally placed nozzle which is water cooled. Two versions were produced weighing 603 kg and 768 kg and of rated capacities of  $130 \text{ Nm}^3/\text{hr}$  and  $200 \text{ Nm}^3/\text{hr}$ , respectively. The preferred fuels were anthracite and coke.

The Stinnes system in Fig. 49 uses updraft with gas exit through a ring chamber above the hearth zone. Water is led from a separate water tank to the ash pit when starting. Later, steam is produced in the water jacket enveloping the hearth.

An installation intended for locomotives and construction equipment was produced under the name A.G.M. and is shown in Fig. 50. It has updraft and steam injection, the steam being produced in an evaporation chamber adjoining the stack wall. The fuels were anthracite and coke.

A rather elaborately designed Deutz system is shown in Fig. 51. Steam is injected into the updraft air stream, the water being preheated first in the tank at the top of the stack and thereafter in the grooves encircling the stack wall. Finally, steam is produced in the jacket around the hearth zone.

The rated capacity is  $100 \text{ Nm}^3/\text{hr}$  at a fully loaded weight of 575 kg.

A wood burning installation is finally shown in Fig. 52, identified merely as an E-pegasus. It is a small and compact layout designed to produce  $60 \text{ Nm}^3/\text{hr}$  at a fully loaded weight of 560 kg.

It should be obvious from the foregoing examples that the final form and the individual details are limited only by the designer's imagination. After fixing certain parameters, e.g. the fuel to be used, the shape and size of vehicle on which the pegasus will be mounted, and the desired capacity of the stack, the design details become a matter of personal preference.

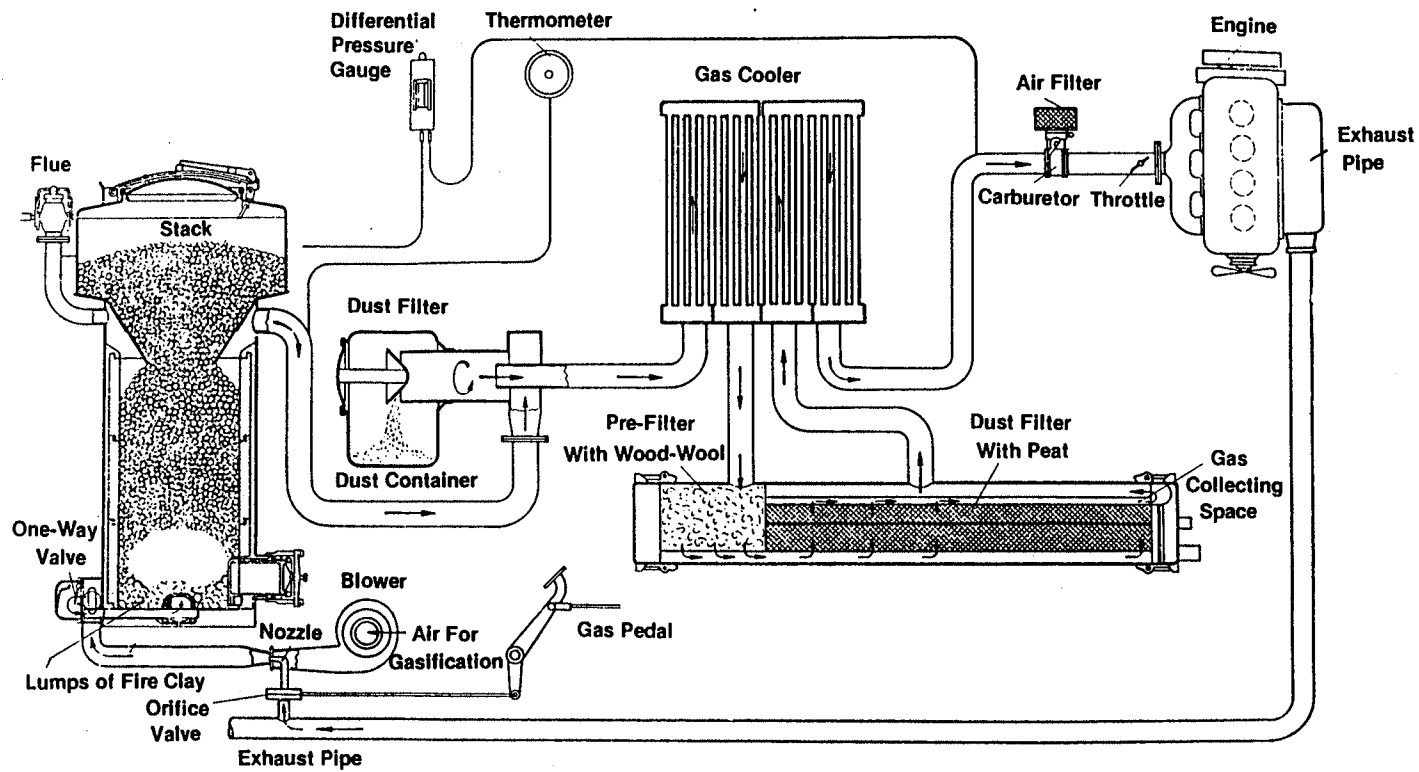

FIG. 42 PEGASUS OF DEUTZ DESIGN, DRY GASIFICATION

THE PEGASUS UNIT

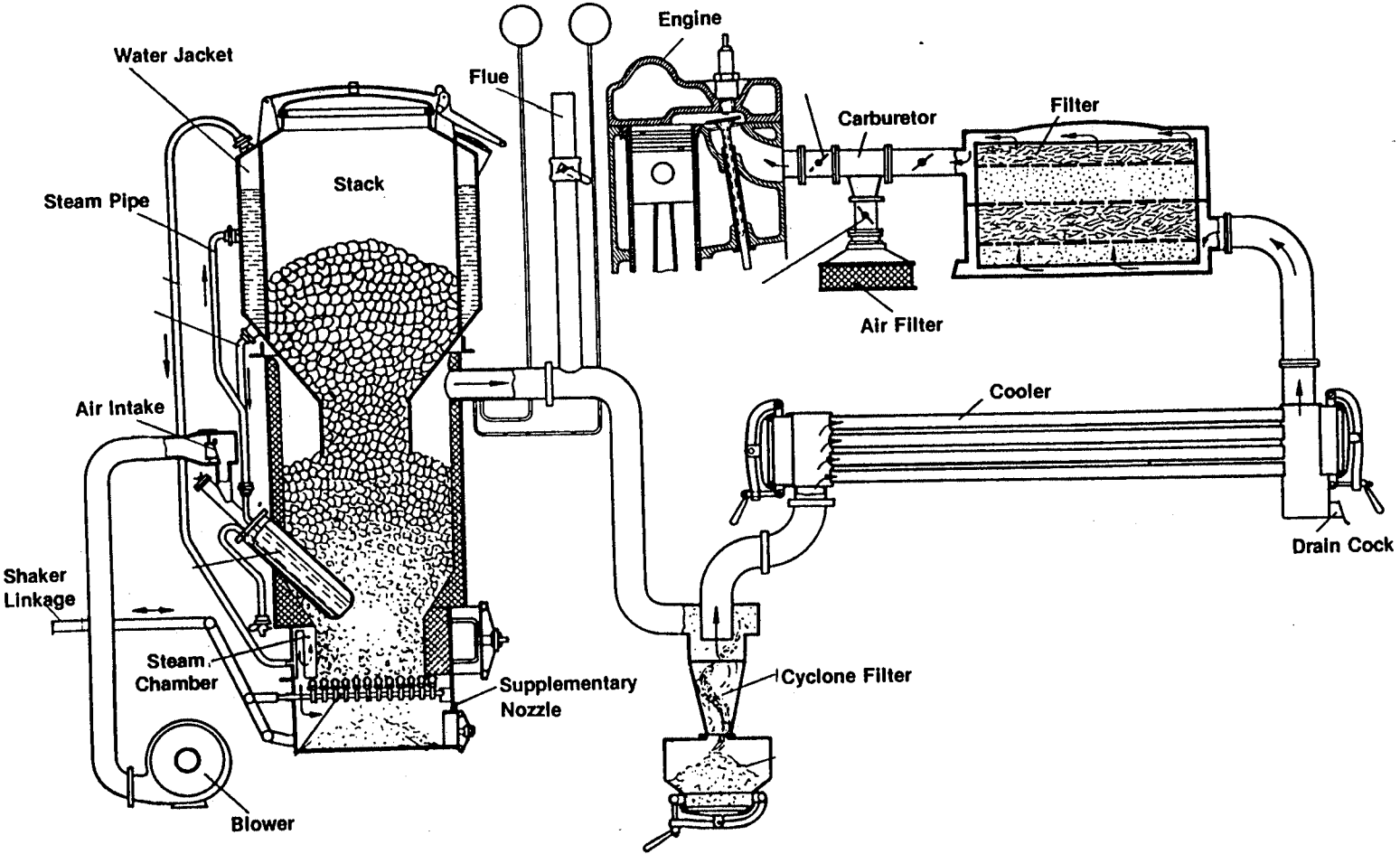

FIG. 43 PEGASUS OF HENSCHEL DESIGN

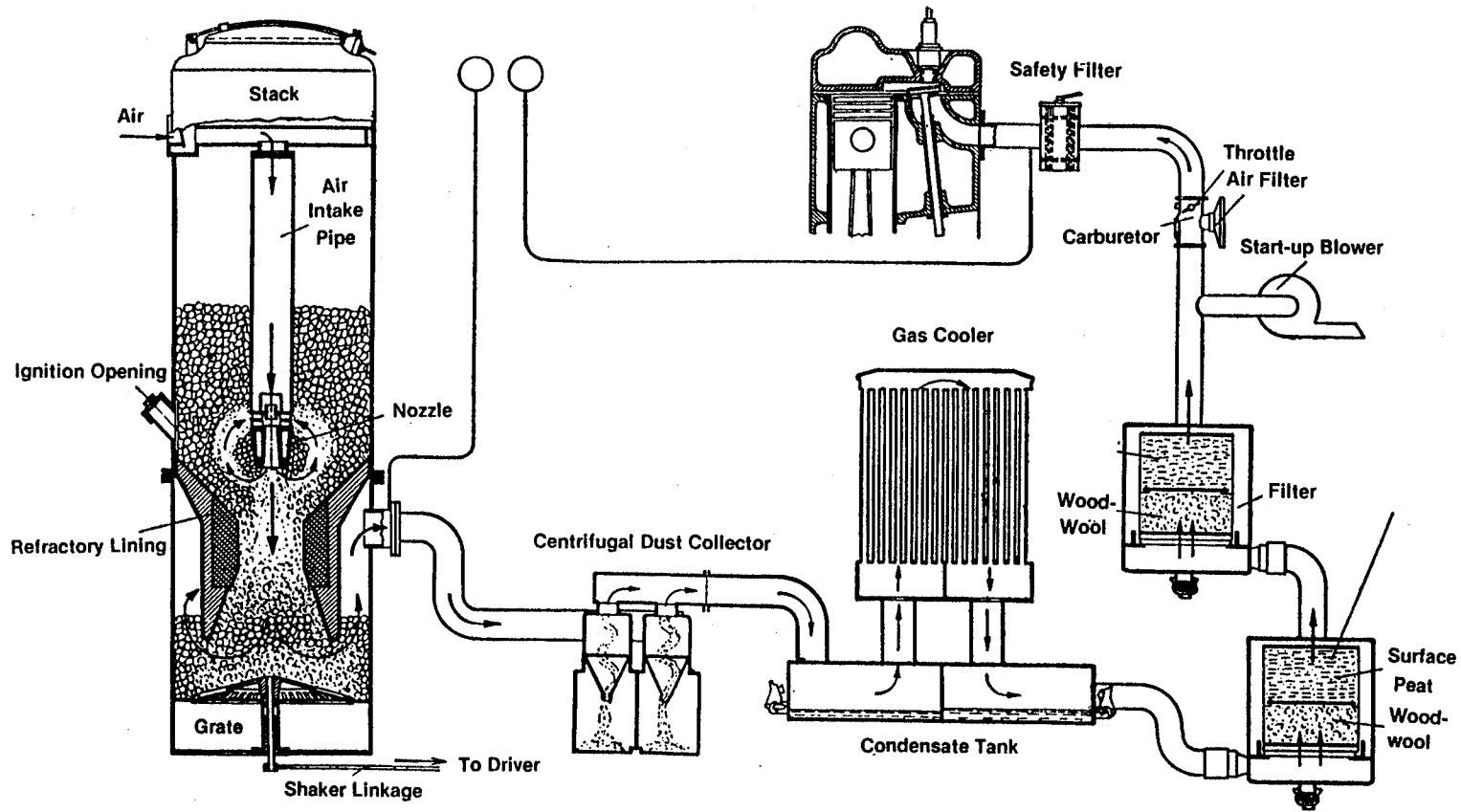

FIG. 44: PEGASUS OF ZEISSL DESIGN.

THE PEGASUS UNIT

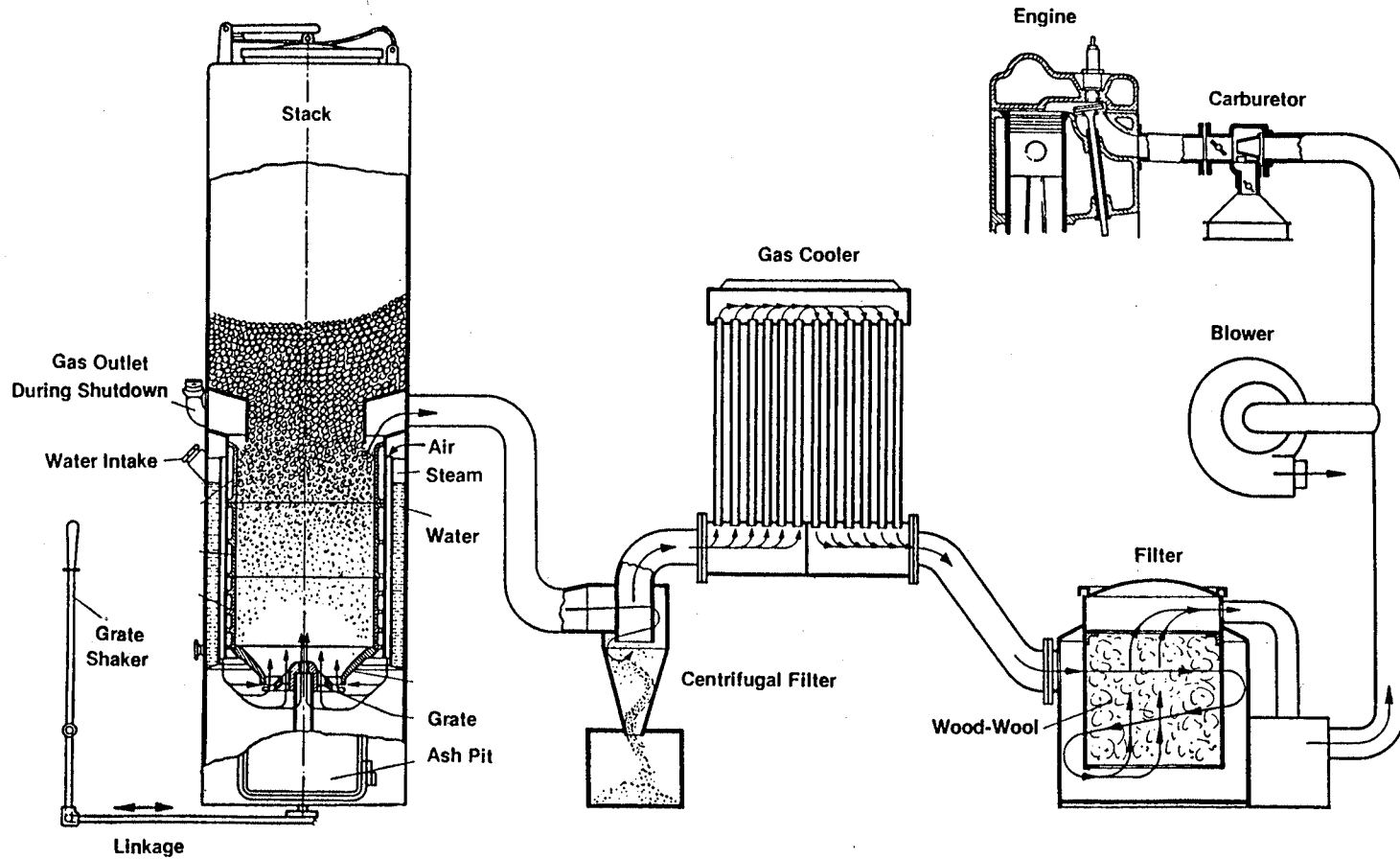

FIG. 45: PEGASUS OF GRUNERT DESIGN.



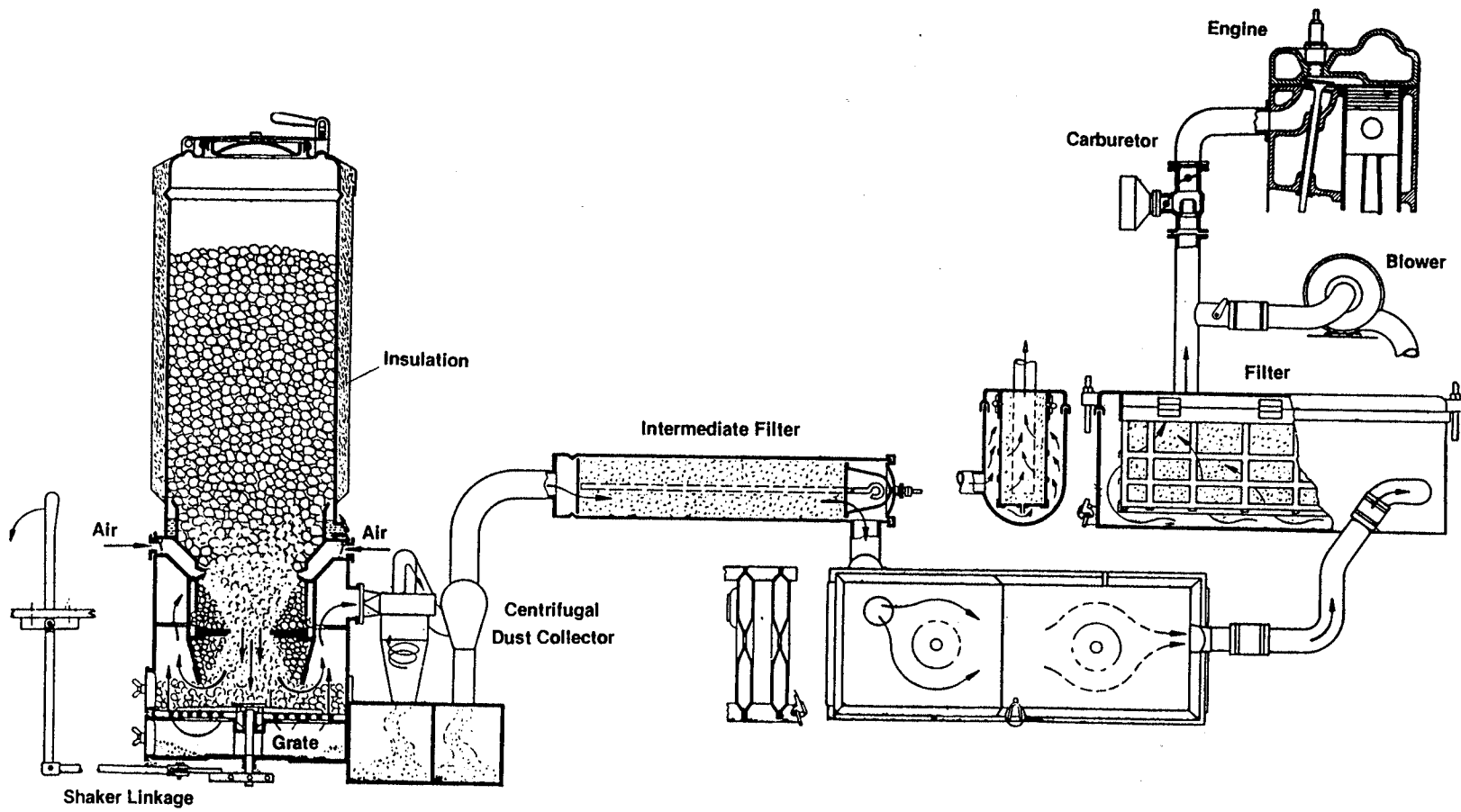

FIG. 46 PEGASUS OF ZEUCH DESIGN

THE PEGASUS UNIT

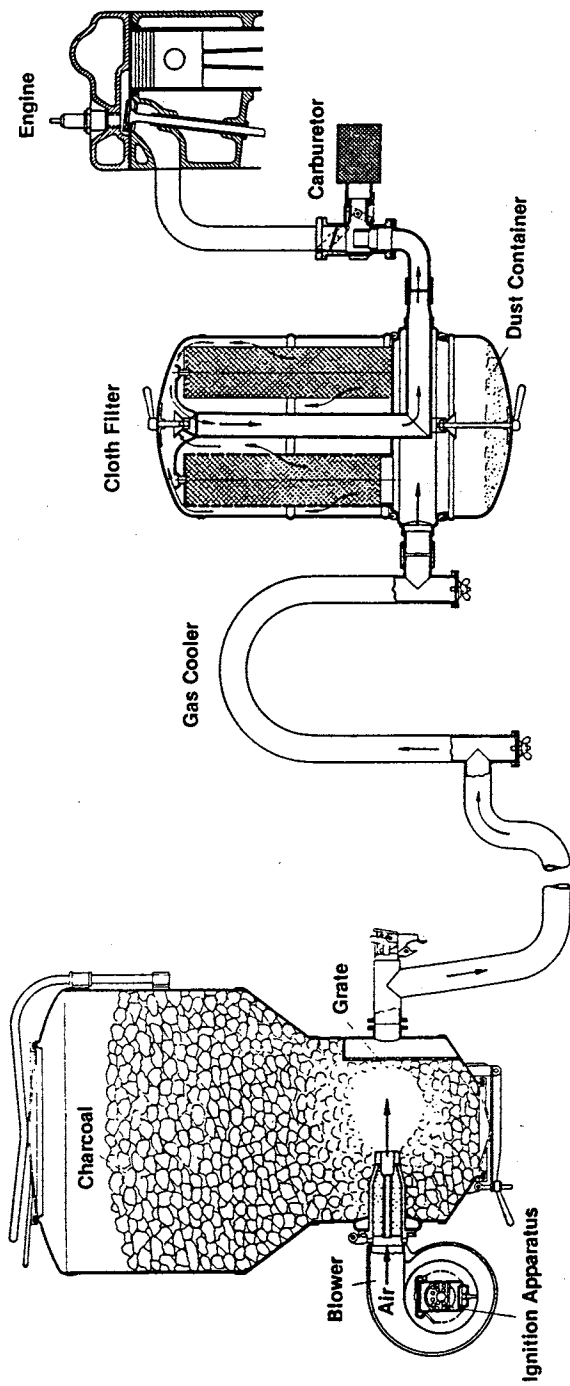

FIG. 47 PEGASUS OF MERCEDES—BENZ DESIGN

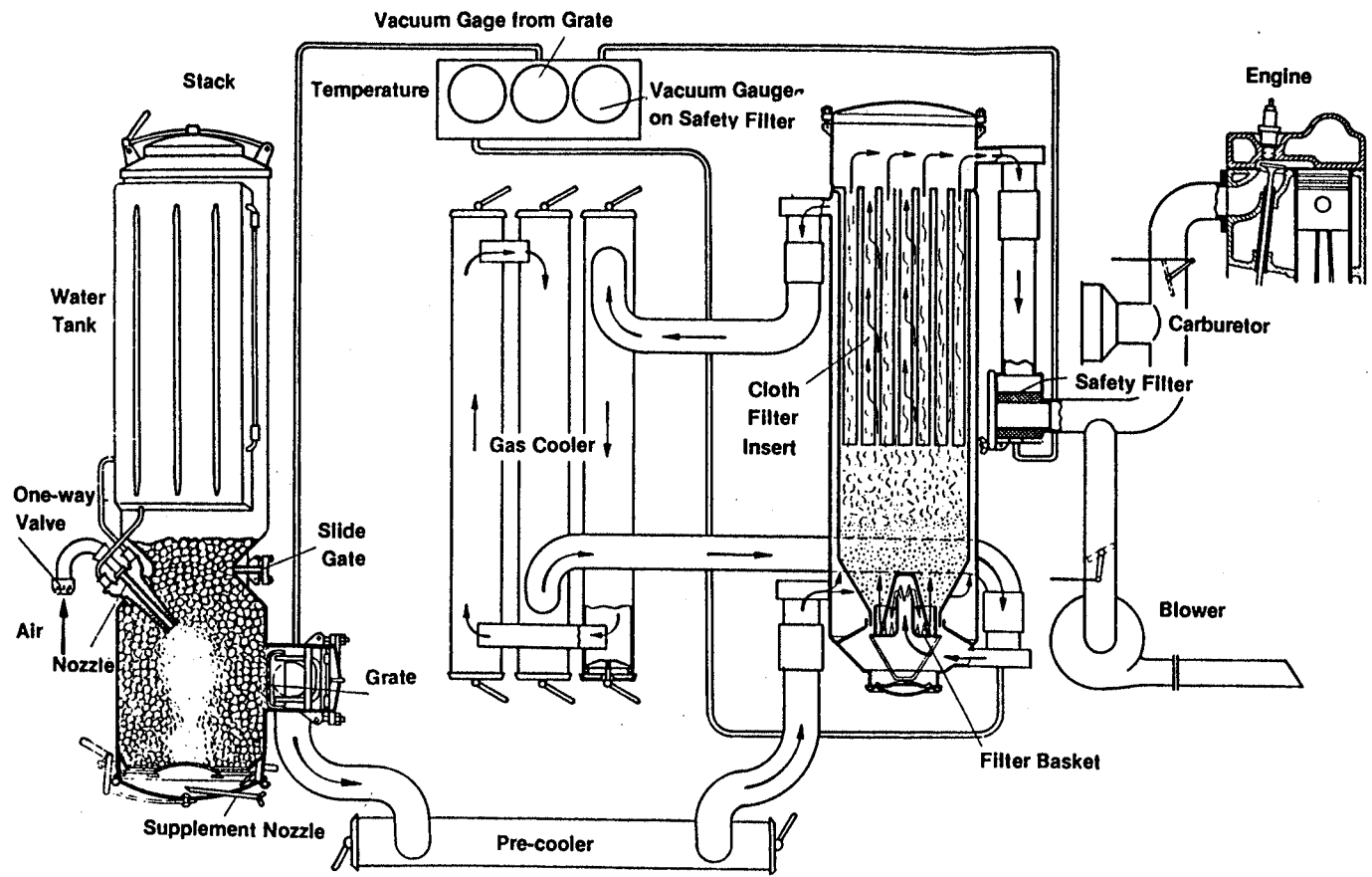

FIG. 48 PEGASUS OF MERCEDES—BENZ DESIGN

THE PEGASUS UNIT

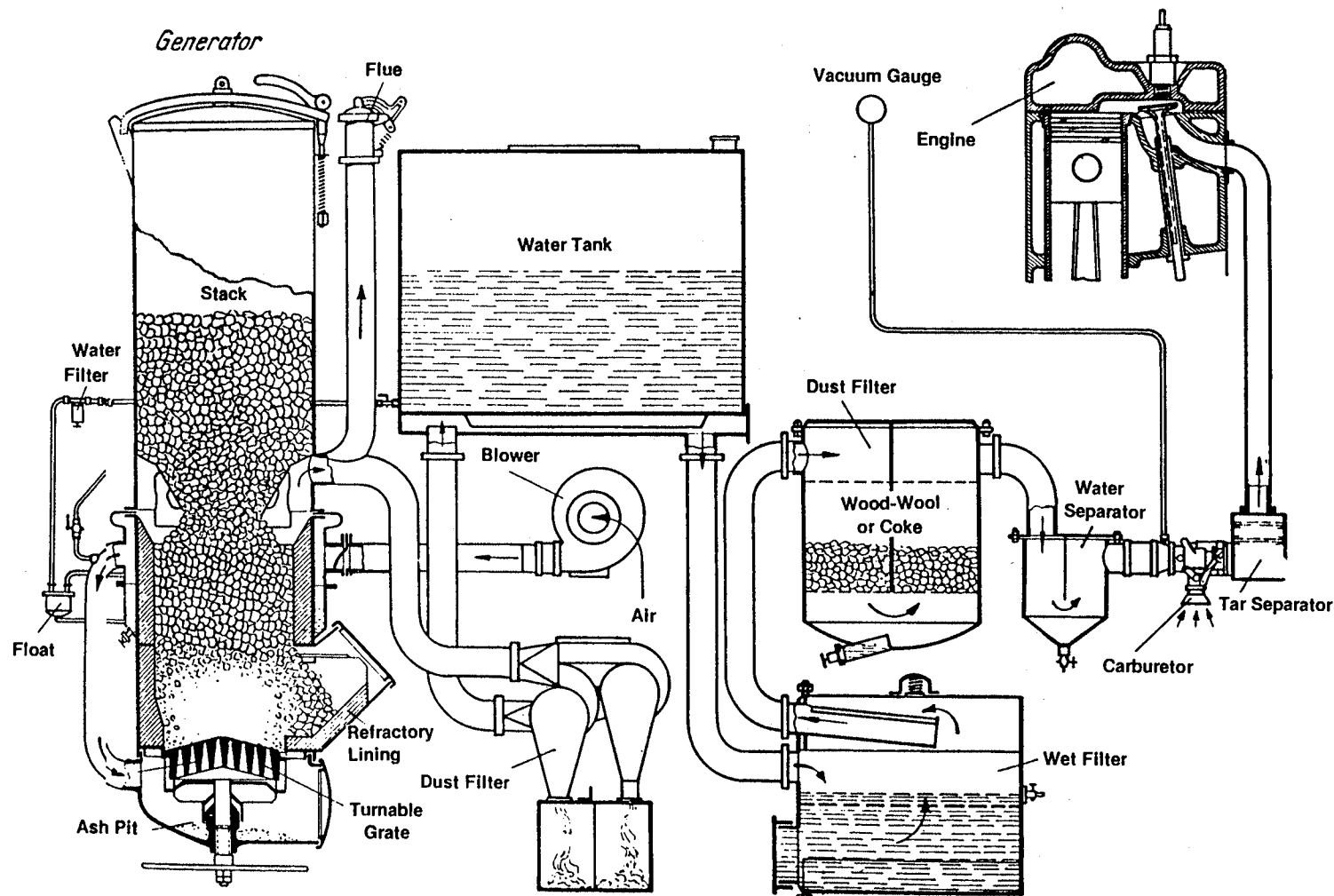

FIG. 49: PEGASUS OF STINNES DESIGN

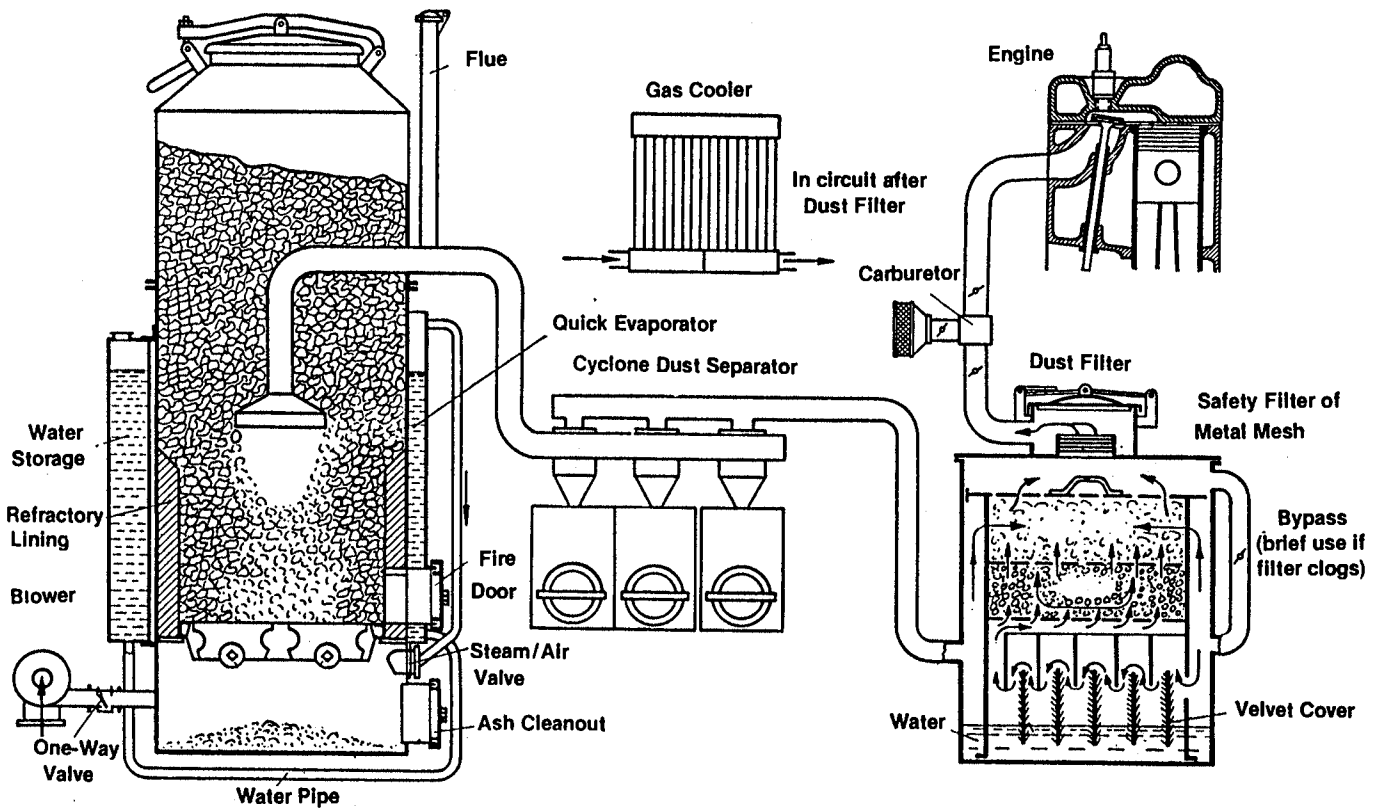

FIG. 50: PEGASUS OF AGM DESIGN.

THE PEGASUS UNIT

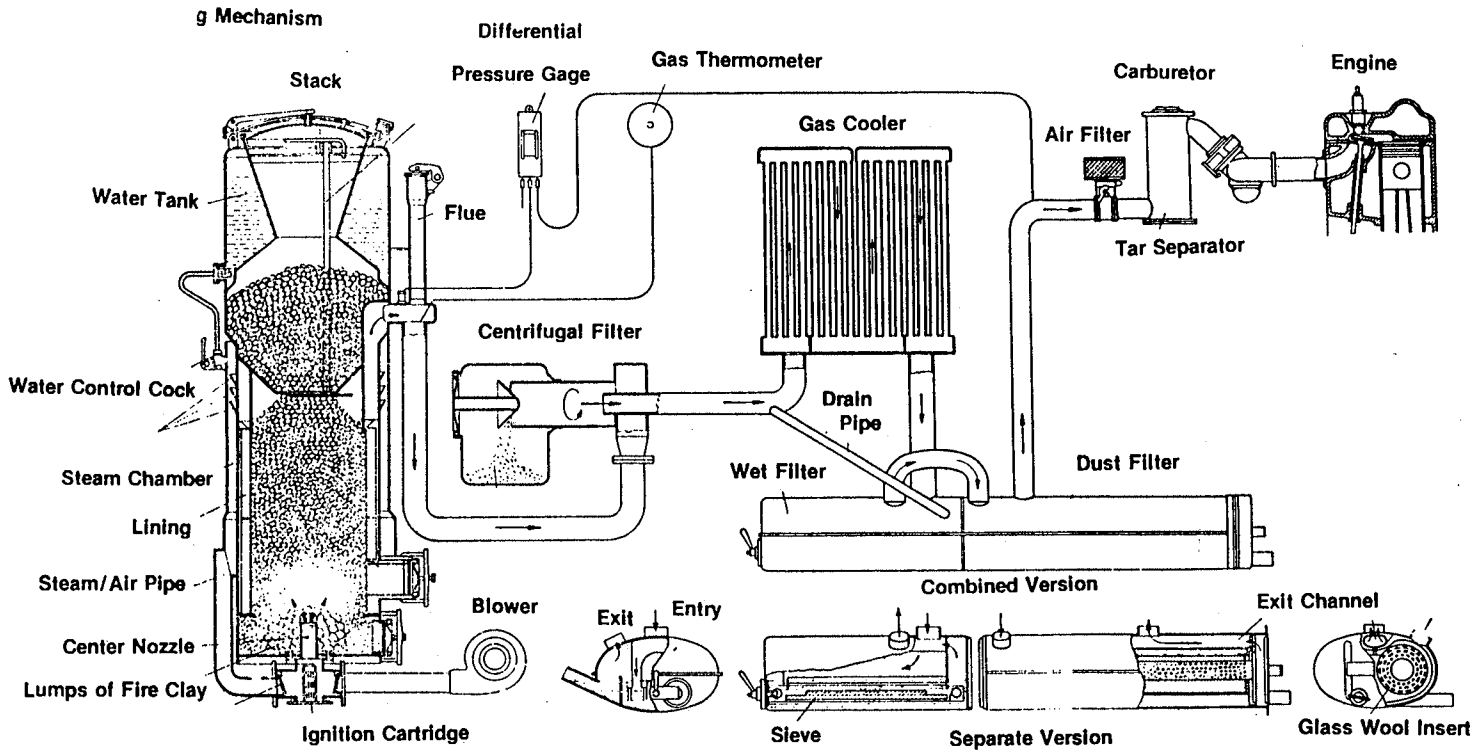

FIG. 51: PEGASUS OF DEUTZ DESIGN, WET GASIFICATION

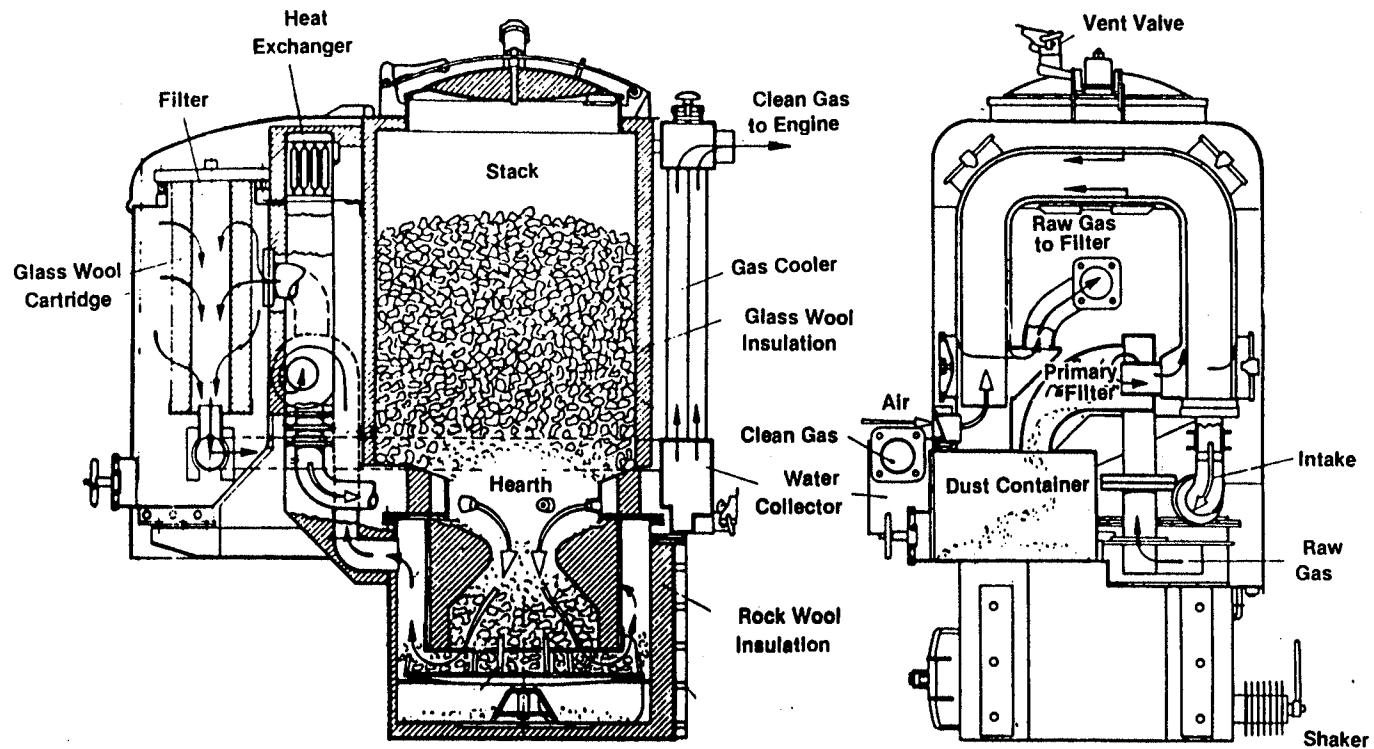

FIG. 52: WOOD BURNING PEGASUS.

THE PEGASUS UNIT

## CONVERSION FACTORS

Length	1 meter (m) = 39.37 in. = 3.281 ft. = $6.214 \times 10^{-4}$ mile 1 in. = 0.0254 m; 1 ft. = 0.3048 m; 1 mile = 1,609 m
Area	1 m <sup>2</sup> = 10.76 ft <sup>2</sup> = 1,550 in <sup>2</sup> = 1.308 yd. <sup>2</sup> 1 ft <sup>2</sup> = 929 cm <sup>2</sup> ; 1 in <sup>2</sup> = 6.452 cm <sup>2</sup>
Volume	1 m <sup>3</sup> = 35.31 ft. <sup>3</sup> = $6.102 \times 10^4$ in. <sup>3</sup> = 264.12 U.S. gallons 1 ft. <sup>3</sup> = 0.02832 m <sup>3</sup> ; 1 U.S. gallon = 231 in. <sup>3</sup> 1 liter = 61.02 in. <sup>3</sup> ; 1 Imp. gallon = 268.8 in. <sup>3</sup>
Speed	1 m/sec = 3.281 ft./sec = 3.6 km/hr = 2.237 mi/hr 1 km/hr = 0.2778 m/sec = 0.9113 ft./sec = 0.6214 mi/hr
Weight	1 kg = 2.205 lb (avoirdupois); 1 metric ton = 1,000 kg 1 short ton = 907.2 kg; 1 long ton = 1,016 kg 1 cwt = 112 lb (avoirdupois) = 50.80 kg
Density	1 g/cm = 1,000 kg/m <sup>3</sup> = 62.43 lb mass/ft <sup>3</sup> = 1.940 slug/ft <sup>3</sup> 1 lb mass/ft <sup>3</sup> = 0.01602 g/cm <sup>3</sup> = 16.02 kg/m <sup>3</sup>
Work,	1 joule = 0.2389 cal = $9.481 \times 10^{-4}$ BTU = 0.7376 ft-lb
Energy,	1 kcal = 4,186 joule = 3.968 BTU = 3,087 ft-lb
Heat	1 cal/g = 1.8 BTU/lb
Power	1 hp = 2545 BTU/hr = 550 ft-lb/sec = 745.7 watt 1 watt = $2.389 \times 10^{-4}$ kcal/sec = $1.341 \times 10^{-3}$ hp



## METRIC UNITS

### Length

1 micron,  $1\mu$  =  $10^{-6}\text{m}$

1 millimeter, 1 mm =  $10^{-3}\text{m}$

1 centimeter, 1 cm =  $10^{-2}\text{m}$

1 meter, 1 m

1 kilometer, 1 km =  $10^3\text{m}$

### Volume

1 liter, 1 l =  $10^3\text{cm}^3$

### Weight

1 kilogram, 1 kg =  $10^3$  gram, g

### Speed

1 km/hr = 27.8 cm/sec

## EXPLANATION OF UNITS USED

A number of grams of an element (or compound) equal to the element's molecular weight is called one gram-mole or one mole of the element. Hence, we have—

$$1 \text{ mole CO}_2 = 12 + (2 \times 16) = 44\text{g.}$$

$$\text{or } 1 \text{ kmole CO}_2 = 12 + (2 \times 16) = 44 \text{ kg.}$$

The quantity of one cubic meter of a dry gas at a temperature of 0° C. and at a pressure of 760 mm of mercury is referred to as one Norm-cubic meter, or—

$$1 \text{ Nm}^3$$

For the purpose of computation it is well to know that for any given gas—

$$1 \text{ kmole} = 22.4 \text{ Nm}^3$$

or conversely,

$$1 \text{ Nm}^3 = 1/22.4 \text{ kmole}$$

We thus can find the weight of one Nm<sup>3</sup> of carbon dioxide as follows:

$$1 \text{ Nm}^3 \text{ CO}_2 = 1/22.4 [12 + (2 \times 16)] = 1.96 \text{ kg.}$$

# INDEX

Abelson, Philip H. 12  
A.G.M. design 114, 123  
air-gas generators 19  
air intake 104, 105, 108  
Alpine Test Drive 22  
ash content 71, 72  
ash removal 72, 73, 79, 80  
blower 112  
calorific value (def.) 51  
center nozzle 83, 85  
ceramic hearth 101, 102  
Club of Rome 16  
combustion zone thickness 53  
Consolidated Edison 12  
cost of oil 12  
cotton bolls 20  
crossdraft 84, 85  
Deutz design 113, 115, 124  
diagonal draft 81, 86, 87  
Diesel, Rudolf 20  
dissociation 38, 44, 49, 50  
downdraft pegasus 48, 82, 85  
dust 68  
early pioneers 20  
electrical cars 17  
endothermic process 42  
energy shortage 11  
engine exhausts 109  
filters 110, 111  
flue 112  
free heat 38  
fuel calorific values 68  
fuel cells 15  
fuel composition 88  
fuel responsiveness 40, 74, 75, 80  
gas composition 88, 89  
gas cooler 111  
gas exit 104

gas temperature 92  
gasification diagram 45  
gasification losses 58  
gasoline consumption 11  
gasoline yield 12  
Generatorstab 23  
Gragas 27  
grain size 66  
grate 102, 103  
Grunert design 113, 118  
heat budget 59  
Henschel design 113, 116  
Hitler 25  
hygroscopic moisture 69  
Imbert design 95  
Kalle 27  
Kohoutek 11  
Long Island Lighting 12  
mass transit 17  
Mercedes-Benz design 114, 120, 121  
mileage 26  
nozzles 106, 107  
nuclear energy 15  
Otto engine 20  
Panzertruppschule 24  
pegasus (def.) 30  
petroleum demand 13  
plant fiber 19  
Quisling 24  
Reickskuratorium 23  
semi-combustion 36, 37, 41, 46  
sliding gate 96, 97  
solar energy 15  
Speer, A. 25  
steam injection 108  
Stinnes design 99, 114, 122  
stove 9, 24  
suction gas engine 19

Svedlund 27  
systemic inertia 56, 57  
tar 69  
throat plate 100  
Third Reich 25  
tidal power 15  
updraft pegasus 78, 79, 81  
Vichy 24  
volatile matter 33, 74  
Volvo 28  
Wehrmacht 23, 24  
wheat chaff 20  
wood analyses 62, 63  
wood consumption 25, 26  
wood gas sickness 27  
World Power Conference 18  
Zeissl design 113, 117  
Zentralstelle fur Generatoren 24  
Zeuch design 113, 119

## BIBLIOGRAPHY

Academy of Sciences of Swedish Engineering. *Gengas*. Stockholm. 1950.

Allan, Leslie, E. K. Kaufman and J. Underwood, et al., Council on Economic Priorities. *Paper Profits: Pollution in the Pulp and Paper Industry*. M.I.T. Press, Cambridge, Mass. 1972.

*Chemical Engineers Handbook*. McGraw-Hill, New York. 1963.

Danmarks Teknologiske Institut. *Rapporter*.

*Fem Aars Kamp for Friheden*. Edited by Niels Jørgensen. Alfred G'Hassings Forlag A/S. Copenhagen. 1966.

Fiebelkorn, Heinz. Oberinspektor an der Panzertruppenschule in Weunsdorf. *Fahrzeug-Dieselmotoren und Fahrzeug Gasgeneratoren*. Union Deutsche Verlagsgesellschaft Berlin. Roth & Co. 1938.

Field, D.C. "Internal Combustion Engines." *A History of Technology*. Edited by Ch. Singer, et al. Vol. V. Oxford University Press. 1958.

Finkbeiner, H., *Hochleistungs Gaserzeuger für Fahrzeugbetrieb und Kleinantriebe*. Springer, Berlin. 1937.

*Gas Engineers Handbook*. McGraw. 1934.

Jantsch, F., Zentralstelle für Generatoren beim Generalbevollmächtigten für Rüstungsaufgaben. Reichsmarschal Speer. *Fahrzeugsgeneratoren*. Joh. Kasper & Co. Berlin. 1943.

*Motor*. Copenhagen. April 1974.

United Nations Economic Commission for Europe. *Trends in Fuel Consumption*. Geneva. 1956.

World Power Conference. *Transactions*. Stockholm. 1934.

# BOOKS FROM THE BIOMASS ENERGY FOUNDATION PRESS

**NEW: A SURVEY OF BIOMASS GASIFICATION 2000:** T. Reed and S. Gaur have surveyed the biomass gasification scene for the National Renewable Energy Laboratory and the Biomass Energy Foundation. 180 pages of large gasifiers systems, small gasifiers and gasifier research institutions with descriptions of the major types of gasifiers and a list of most world gasifiers. ISBN 1-890607-13-4 180 pp \$25 \_\_\_\_\_

**NEW: BIOMASS GASIFIER "TARS": THEIR NATURE, FORMATION, AND CONVERSION:** T. Milne, N. Abatzoglou, & R. J. Evans. Tars are the Achilles Heel of gasification. This thorough work explores the chemical nature of tars, their generation, and methods for testing and destroying them. ISBN 1-890607-14-2 180 pp \$25 \_\_\_\_\_

**NEW: EVALUATION OF GASIFICATION AND NOVEL THERMAL PROCESSES FOR THE TREATMENT OF MUNICIPAL SOLID WASTE -** W. Niessen et al. 1996 NREL report by Camp Dresser and McKee on MSW conversion processes. ISBN 1-890607-15-0 198 pp \$25 \_\_\_\_\_

**NEW: FROM THE FRYER TO THE FUEL TANK: HOW TO MAKE CHEAP, CLEAN FUEL FROM FREE VEGETABLE OIL:** J. & K. Tickell, (1998) Resale from Greenteach Publishing Co. Tickell has done an excellent job of collecting both theory and praxis on producing Biodiesel fuel from vegetable oils, particularly used oil. Nice instructions for kitchen or large scale. ISBN 0-9664616-0-6 90 pp \$20 \_\_\_\_\_

**NEW/OLD: DENSIFIED BIOMASS: A NEW FORM OF SOLID FUEL:** Tom Reed and Becky Bryant, A "State of the Art evaluation of densified biomass fuels" with documentation of processes, energy balance, economics and applications. First published in 1978, & still good. ISBN 1-890607-16-9 35 pp \$12 \_\_\_\_\_

**NEW/OLD: MODERN GAS PRODUCERS:** N. E. Rambush, the most complete collection of information on the golden age of coal gasification, when every city had a "gasworks". 550 pp \$30 \_\_\_\_\_

**NEW/OLD: FREE ENERGY OF BINARY COMPOUNDS: AN ATLAS OF CHARTS FOR HIGH-TEMPERATURE CALCULATIONS, 2<sup>nd</sup> edition,** Thomas B. Reed, MIT Press, 1971. 90 pp \$20 \_\_\_\_\_

\*\*\*\*\*

**BIOMASS DOWNDRAFT GASIFIER ENGINE SYSTEMS HANDBOOK:** T. Reed and A. Das, (SERI-1988) Over a million wood gasifiers were used to power cars and trucks during World War II. Yet, after over two decades of interest, there are only a few companies manufacturing gasifier systems. The authors have spent more than 20 years working with various gasifier systems, in this book they discuss ALL the factors that must be correct to have a successful "gasifier power system." Our most popular book, the "new Testament" of gasification ISBN 1-890607-00-2 140 pp \$25 \_\_\_\_\_

**GENGAS: THE SWEDISH CLASSIC ON WOOD FUELED VEHICLES:** English translation, (SERI-1979) T. Reed, D. Jantzen and A. Das, with index. This is the "Old Testament" of gasification, written by the people involved in successfully converting 90% of transportation of WW II Sweden to wood gasifiers. ISBN 1-890607-01-0 340 pp. \$30 \_\_\_\_\_

**SMALL SCALE GAS PRODUCER-ENGINE SYSTEMS:** A. Kaupp and J. Goss. (Veiweg, 1984) Updates GENGAS and contains critical engineering data indispensable for the serious gasifier projects. Ali Kaupp is thorough and knowledgeable. ISBN 1-890607-06-1 278 pp \$30 \_\_\_\_\_

**PRODUCER-GAS: ANOTHER FUEL FOR MOTOR TRANSPORT:** Ed. Noel Vietmeyer (The U.S. National Academy of Sciences-1985) A seeing-is-believing primer with historical and modern pictures of gasifiers. An outstanding text for any introductory program. ISBN 1-890607-02-6 80 pp \$10 \_\_\_\_\_

**FUNDAMENTAL STUDY AND SCALEUP OF THE AIR-OXYGEN STRATIFIED DOWNDRAFT GASIFIER:** T. Reed, M. Graboski and B. Levie (SERI 1988). In 1980 the Solar Energy Research Institute initiated a program to develop an oxygen gasifier to make methanol from biomass. A novel air/oxygen low tar gasifier was designed and studied for five years at SFRI at 1 ton/d and for 4 years at Sun-Gas Inc. in a 25 ton/day gasifier. This book

describes the theory and operation of the two gasifiers in detail and also discusses the principles and application of gasification as learned over eight years by the author-gasifier team.  
ISBN 1-890607-03-7 290 pp \$30 \_\_\_\_\_

**CONTAMINANT TESTING FOR GASIFIER ENGINE SYSTEMS:** A. Das (TIPI 1989). Test that gas for tar! Long engine life and reliable operation requires a gas with less than 30 mg of tar and particulates per cubic meter (30 ppm). The simplified test methods described here are adapted from standard ASTM and EPA test procedures for sampling and analyzing char, tar and ash in the gas. Suitable for raw and cleaned gas. New edition & figures, 1999. ISBN 1-890607-04-5 32 pp \$10 \_\_\_\_\_

**TREE CROPS FOR ENERGY CO-PRODUCTION ON FARMS:** Tom Milne (SERI 1980) Evaluation of the energy potential to grow trees for energy. ISBN 1-890607-05-3 260 pp \$30 \_\_\_\_\_

**WOOD GAS GENERATORS FOR VEHICLES:** Nils Nygard's (1973). Translation of recent results of Swedish Agricultural Testing Institute. ISBN 1-890607-08-8 50 pp. \$4 \_\_\_\_\_

**CONSTRUCTION OF A SIMPLIFIED WOOD GAS GENERATOR:** H. LaFontaine (1989) - Over 25 drawings and photographs on building a gasifier for fueling IC engines in a Petroleum Emergency (FEMA RR28). ISBN 1-890607-11-8 68 pp \$15 \_\_\_\_\_

**BIOMASS TO METHANOL SPECIALISTS' WORKSHOP:** Ed. T. Reed and M. Graboski, 1982. Expert articles on conversion of biomass to methanol. ISBN 1-890607-10-X 331 pp \$30 \_\_\_\_\_

**THE PEGASUS UNIT: THE LOST ART OF DRIVING WITHOUT GASOLINE:** N. Skov and M. Papworth, (1974). Description and beautiful detailed drawings of various gasifiers and systems from World War II. ISBN 1-890607-09-6 80 pp \$20 \_\_\_\_\_

**GASIFICATION OF RICE HULLS: THEORY AND PRAXIS:** A. Kaupp. (Veiweg, 1984) Applies gasification to rice hulls, since rice hulls are potentially a major energy source - yet have unique problems in gasification. ISBN 1-890607-07-X 303 pp \$30 \_\_\_\_\_

**TREES:** by Jean Giono, 1953. While we strongly support using biomass for energy, we are also very concerned about forest destruction. This delightful story says more than any sermon on the benefits and methods of reforestation. ISBN 1-89060712-6 8 pp \$1 \_\_\_\_\_



# ORDER LIST - Biomass Energy Books

(Nicknames in **Bold**, book descriptions follow)

1. A SURVEY OF BIOMASS GASIFICATION 2000:	\$25
2. BIOMASS DOWNDRAFT GASIFIER ENGINE SYSTEMS HANDBOOK:	\$25
3. <b>CONTAMINANT TESTING FOR GASIFIER ENGINE SYSTEMS:</b>	\$10
4. BIOMASS <b>GASIFIER "TARS": THEIR NATURE, FORMATION, AND CONVERSION:</b>	\$25
5. <b>GENGAS: THE SWEDISH CLASSIC ON WOOD FUELED VEHICLES:</b>	\$30
6. <b>SMALL SCALE GAS PRODUCER ENGINE SYSTEMS:</b>	\$30
7. <b>PRODUCER-GAS: ANOTHER FUEL FOR MOTOR TRANSPORT:</b>	\$10
8. <b>FUNDAMENTAL STUDY AND SCALEUP OF THE AIR-OXYGEN STRATIFIED DOWNDRAFT GASIFIER:</b>	\$30
9. <b>EVALUATION OF GASIFICATION AND NOVEL THERMAL PROCESSES FOR THE TREATMENT OF MUNICIPAL SOLID WASTE - MSW</b>	\$25
10. <b>DENSIFIED BIOMASS: A NEW FORM OF SOLID FUEL:</b>	\$12
11. <b>WOOD GAS GENERATORS FOR VEHICLES:</b>	\$4
12. <b>CONSTRUCTION OF A SIMPLIFIED WOOD GAS GENERATOR:</b>	\$15
13. <b>BIOMASS TO METHANOL SPECIALISTS' WORKSHOP:</b>	\$30
14. <b>THE PEGASUS UNIT: THE LOST ART OF DRIVING WITHOUT GASOLINE:</b>	\$20
15. <b>GASIFICATION OF RICE HULLS: THEORY AND PRAXIS:</b>	\$30
16. <b>TREES:</b>	\$1
17. <b>TREE CROPS FOR ENERGY CO-PRODUCTION ON FARMS:</b>	\$30
18. <b>FROM THE FRYER TO THE FUEL TANK: HOW TO MAKE CHEAP, CLEAN FUEL FROM FREE VEGETABLE OIL:</b>	\$20
19. Modern Gas Producers by N. E. <b>Rambush</b> (1923)	\$30
20. <b>Free Energy of Binary Compounds</b>	\$25

TOTAL FOR BOOKS \_\_\_\_\_

### ORDER BLANK

-10% if 3 or more books ordered or to booksellers **\$3 handling** + (US and Canada

**\$1.50** (bookrate, or request air, \$3) or (other foreign, \$9/large book- air only) \_\_\_\_\_

### TOTAL ORDER \_\_\_\_\_

E-mail order to reedtb2@CS.com or Mail orders to The Biomass Energy Foundation Press (BEFP), 1810 Smith Rd., Golden, CO 80401; FAX 303-278 0560; call 303 278 0558. We'll send invoice with books. Pay by postal order or check on US Banks (no foreign), or electronic deposit to Bank No. 10 20000 76, Acct. No. 300800 2911.

